

# NeuroOrthopaedics – Kids

Devices for children



Quality for life

# Our promise



Our promise is to provide you as a provider of fittings or services with the best possible resources so that you are in a position to offer and adapt useful and effective devices for your patients – in this case, children.

Laughing, playing and being happy together – social interaction is essential for everyone. Our services and devices help children and parents reduce stress and be more relaxed in their daily lives.

This presents a challenge for suppliers, fitting providers and therapists. Because it's up to us to create the technical and therapeutic conditions for social interaction by selecting the best devices. So children can learn and communicate with others at eye level right from the beginning, while actively exploring and shaping their environment.

Mobilisation is an essential part of this. The more mobile a child is, the easier it will be for them to communicate with their peers. Devices that actively support achieving an upright position against the force of gravity – verticalisation – help the child sit independently, straighten up and move about.

They also reinforce therapeutic progress and promote further development.

Devices should be measured by the extent to which they promote mobility and their suitability for everyday use. Compliance, or the acceptance of the device, plays a pivotal role here. It's often more of a challenge to convince parents to use a device. Children, meanwhile, are naturally curious, which makes them less critical users. This makes it all the more important that the industry and trade form close links with one another and support each other with ideas and assistance in choosing the right products.







# Ottobock's guiding principles

## 1 Promoting personal initiative

Our devices assist the child only as much as necessary. They support and challenge the child so they can become active on their own.

## 2 Creating opportunity for participation (inclusion)

Our devices promote social integration and help the child actively explore their environment.

## 3 Meeting the needs of the individual child

Our devices adapt to the child, not the other way around. Individual adaptation is essential for meeting the specific requirements of the child.

## 4 Comfortable and convenient

Our devices are as comfortable as possible. Their fit and design are based on the individual requirements.

## 5 Supporting therapy

Our devices are based on the therapy objectives, and they promote these objectives even during everyday activities.

## 6 Multiple benefits

Our devices are designed to make the lives of children easier – as well as those of their parents, attendants and therapists. This is why we involve them in the development of our products.

## 7 Making life easier

Our devices are designed for everyday activities and are easy to use.

## Design that matches the requirements

Our devices are designed and optimised according to the indications and requirements of the child. The design has to meet the functional requirements, but is nevertheless tailored to the needs of children.

## Up to date

Ottobock conducts extensive research and supports the scientific community. We incorporate new findings into the development of our products and services. We aspire to be a leading innovator at the cutting edge of research. In order to achieve this, we need your experience with our products so this knowledge can be incorporated into our devices.







# Sensorimotor problems



## ▸ Athetosis

This movement disorder is marked by exaggerated, involuntary movements.

### Appearance

- Muscle tension fluctuates between hypotonic and hypertonic
- Movements are uncontrolled, writhing and unusual

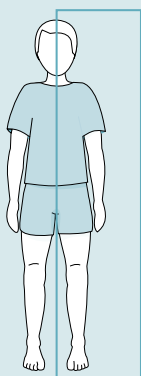

## ▸ Hemiparesis

Movement disorder affecting **one side of the body**.

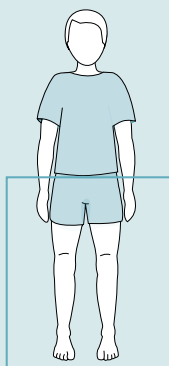

## ▸ Diparesis

Movement disorder that primarily affects the **lower limbs**. However, the upper limbs and the torso may also be affected to varying degrees.

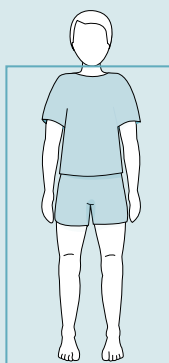

## ▸ Tetraparesis

Movement disorder in which **all four limbs** and the torso are affected.

# Secondary orthopaedic problems

Secondary orthopaedic problems of cerebral palsy depend on the severity of the clinical symptoms and occur frequently. Causes include continuous, abnormal posture and movement patterns resulting from problems with muscle tone, trunk stabilisation and symmetry.

Secondary orthopaedic problems must be diagnosed accurately and taken into consideration when adapting a device. For example, contractures and hip luxations can be very painful and result in increased muscle tension.



## ▸ Contractures

A contracture is the shortening of muscles, tendons or ligaments in a joint. This limits movement or leads to complete stiffness. In children with cerebral palsy, the increased tonicity in the limbs causes shortening of certain muscles depending on the degree of severity and may thus lead to permanent contractures.

**These contractures can have a negative effect on – or even prevent – functions such as sitting, standing and walking.**

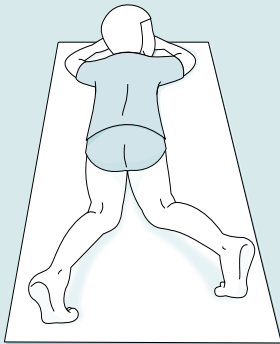

## ▸ Adduction contracture

### Appearance

- Abduction (moving away from the body) is no longer possible
- Typical position of the hips for adduction/internal rotation

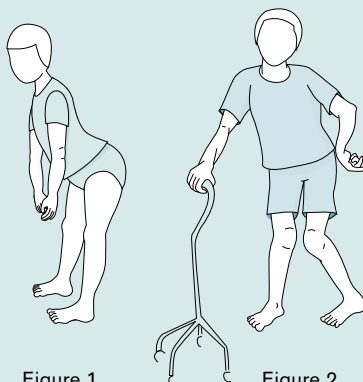

Figure 1

Figure 2

## ▸ Hip flexion contracture

### Appearance

- Hip extension is not possible
- Compensated for while standing by hip flexion and internal rotation while extending the knee (see Figure 1) or hip extension and internal rotation while flexing the knee (see Figure 2)

# Secondary orthopaedic problems

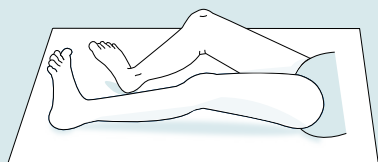

## ▶ Knee flexion contracture

### Appearance

- Knee flexion posture
- Knee extension is not possible



Congenital pes equinus

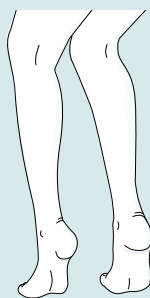

Acquired pes equinus

## ▶ Pes equinus

### Appearance

- Malposition of the foot in which the heel does not contact the ground, and the load is on the forefoot
- Compensated for while standing by knee flexion or hip extension with hyperlordosis (swayback)
- Without treatment, the deformity becomes fixed, which makes standing and walking more difficult because the weight-bearing area is reduced



## ▶ Pes valgus (flat foot)

### Appearance

- Flattened arch, heel leans to the side
- Depending on the degree of severity, treatment with arch supports, orthoses or surgery may be recommended



# Secondary orthopaedic problems

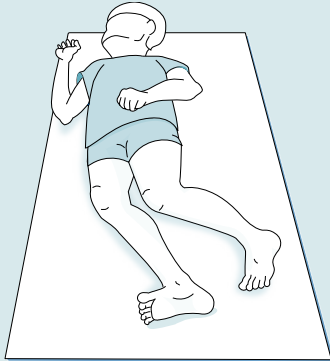

## • Windswept deformity

### Appearance

- Posture-related leaning of the legs to one side due to differences in muscle tone and symmetry on the two sides
- This results in progressive asymmetry of the entire body

**i** If the increasing asymmetry is not addressed early, secondary orthopaedic problems may arise in addition to a windswept deformity, such as hip luxation, joint contractures and scoliosis (abnormal curvature of the spine)

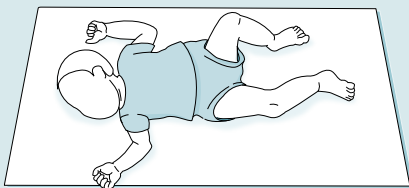

## • Asymmetry

Many children with cerebral palsy suffer from limited stability of the trunk and low muscle activity in the torso (hypotonic torso) as well as asymmetric movements. This frequently leads to malpositions in the affected children. The child may also develop an asymmetry due to inadequate support from the device or from an insufficient fitting.

### Appearance

- This situation arises due to asymmetrical tonicity, movement, spasticity, pain or the continued occurrence of pathological reactions and reflexes
- Unilateral hearing or vision
- Uneven growth of the limbs
- Idiopathic scoliosis (with no obvious cause) can lead to asymmetric movement or posture

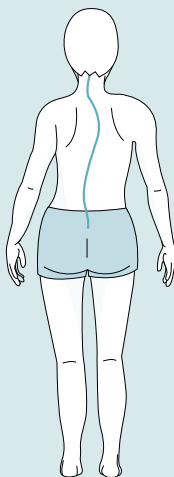

## • Scoliosis (abnormal curvature of the spine)

Scoliosis is a common secondary condition of cerebral palsy or muscular dystrophy, as limited torso stability, low tonicity in the torso and asymmetric movement can occur with these diseases.

The treatment options and prognosis are good if the condition is diagnosed early.

### Appearance

- The spine is curved to the side and the vertebrae are rotated – the spine is no longer able to assume an upright position or be straightened
- One shoulder is higher than the other or a shoulder blade projects dorsally
- The ribs protrude

# Hemiparesis/hemiplegia

**17AD1/17AF2 Conventional ankle joints**  
Page 22

**17AF10 X-ible**  
Page 20

**17F34/17F24 Ankle joint bar for children**  
Page 24

**17CF1 Carbon Ankle seven**  
Seite 25

**16X4 Arm bars**  
Page 62

**16X12 Elbow joint bars**  
Page 60

**17B70 Positioning joint**  
Page 63

**28FS300 L300 Go functional electrical stimulation**  
Page 16

**28U25 WalkOn Reaction junior**  
Page 14

**17AD100 Nexgear Tango ankle joint**  
Page 32

**17LA3N Unilateral ankle joint**  
Page 28

# Diparesis/diplegia

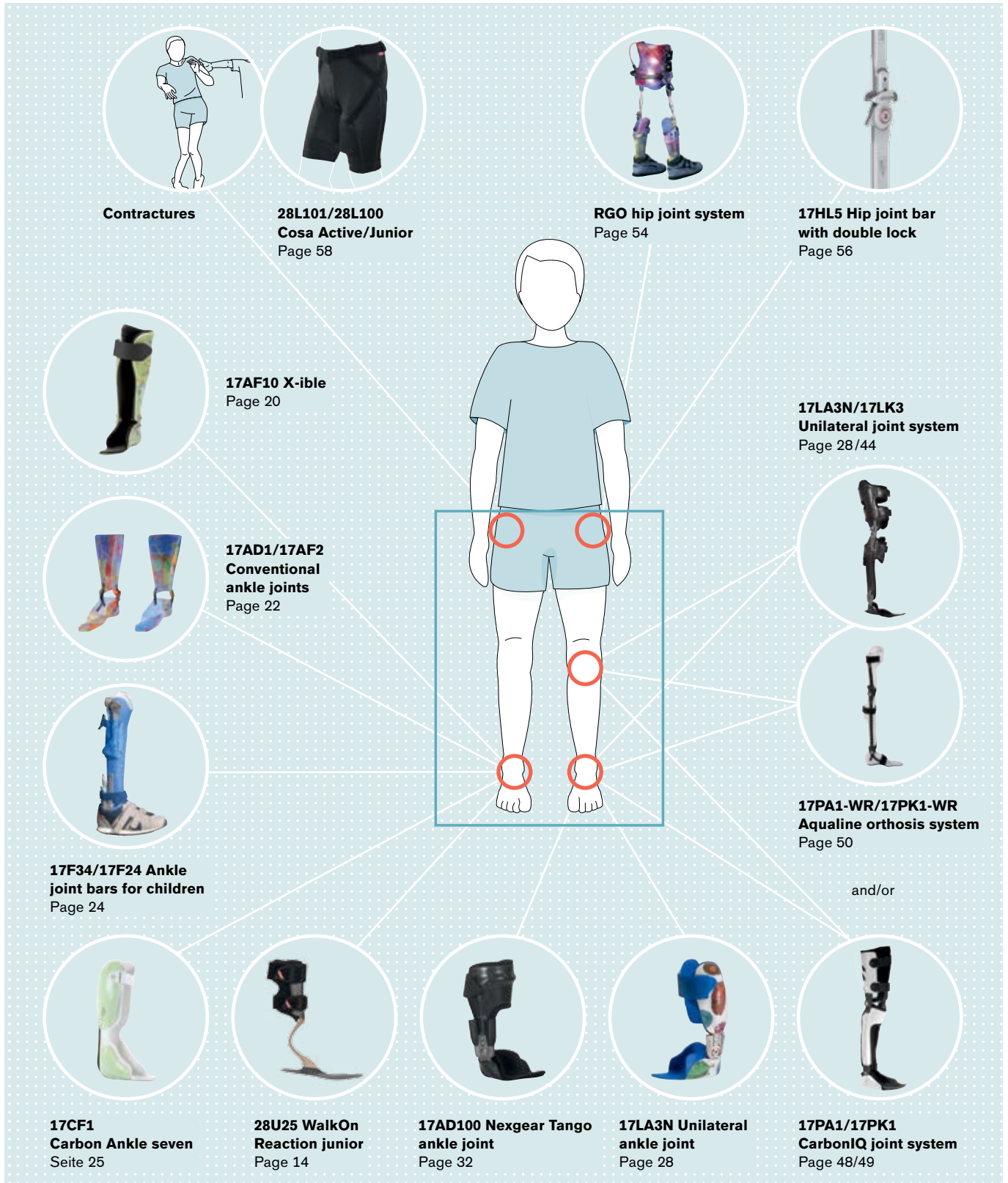

# Tetraplegia/tetraparesis

**Contractures**

**28L101/28L100 Cosa Active/Junior**  
Page 58

**16X4 Arm bars**  
Page 62

**RGO hip joint system**  
Page 54

**16X12 Elbow joint bars**  
Page 60

**17HL5 Hip joint bar with double lock**  
Page 56

**17B70 Positioning joint**  
Page 63

**17F34 / 17F24 Ankle joint bar for children**  
Page 24

**17LA3N/17LK3 Unilateral joint system**  
Page 28/44

**17CF1 Carbon Ankle seven**  
Page 25

**17AD100 Nexgear Tango ankle joint**  
Page 32

**17LA3N Unilateral ankle joint**  
Page 28

**17PA1/17PK1 CarbonIQ joint system**  
Page 48/49

**17PA1-WR/17PK1-WR Aqualine orthosis system**  
Page 50

and/or



# Contractures



**17BK1 Correction system joints**  
Page 64



**17BK2 Dynamic unit for correction system joint**  
Page 66

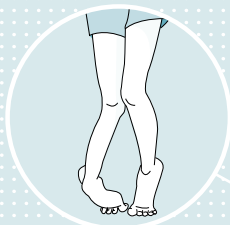

**Scissor gait**

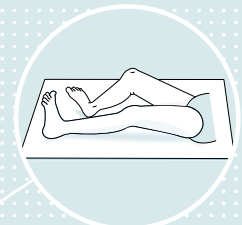
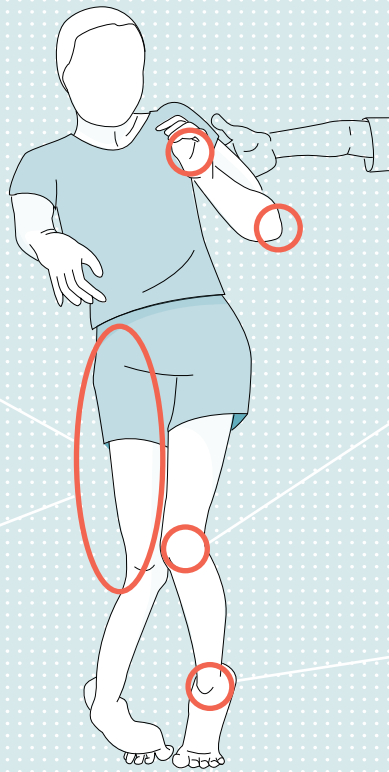

**Contracture of the knee flexors**



**28L101/28L100 Cosa Active/Junior**  
Page 58



**Congenital and acquired pes equinus**



**Pes valgus**

# AFO – Dynamic ankle-foot orthosis

## 28U25 WalkOn Reaction junior

It's so dynamic!



The WalkOn Reaction junior is based on the WalkOn Reaction plus and thus has the same excellent dynamic properties as a dorsiflexion assist orthosis and an inconspicuous, slim design – but is geared towards children.

### How it works

- Supports dorsiflexion
- Promotes dynamic rollover
- Increases the stride length by improving muscle dynamics
- Promotes exterior rotation of the foot at heel strike
- Promotes a physiological gait pattern
- Reduces the risk of falling

### Application

- Infantile cerebral palsy
- Drop foot, without or with mild to moderate spasticity
- Hemiparesis, diparesis

### Special features

- Highly dynamic properties (use of ground reaction force) for better control while walking
- High wearer comfort due to low weight and open heel and the anatomically designed frontal support element
- Can be worn with sturdy standard shoes
- Shin pad made of climate-regulating material for improved skin hygiene; all textile parts are washable and replaceable
- Can be combined with additional dynamic ankle-foot orthoses (DAFOs)

### Our recommendation

The WalkOn Reaction junior can be combined with the following for bilateral fittings:

- 28L100 Cosa Junior
- 28L101 Cosa Active

**Article number 28U25**

Order no.: Article number=side shoe size  
 Example for ordering: 28U25=L24-27



Side	Shoe size	Height (cm)
L/R	24-27	20.5
L/R	27-30	24.5
L/R	30-33	27
L/R	33-36	29.4



A Fit Kit (28T5) is available for the WalkOn Reaction junior, as it is for the other products in the WalkOn line.

## Spare parts for 28U25

### Padding

Article number	Size	Shoe size
29U24	L/R	24-27
	L/R	27-30
	L/R	30-33
	L/R	33-36

### Y-hook-and-loop

Article number	Size
29U25=2	2
29U25=3	3



29U24 padding



29U25 Y-hook-and-loop

## Optional accessory

### Magnetic closure

Article number	For
514Z8=20-7	2 cm wide straps
514Z8=30-7	3 cm wide straps
514Z8=40-7	4 cm wide straps
514Z9=40-7	Slider – for 4 cm wide straps



514Z8 magnetic closure

# Functional electrical stimulation

---

## 28FS300 L300 Go

Improved mobility. Made easier.



The L300 Go system for users with drop foot (e.g. after a stroke) is based on the principle of functional electrical stimulation (FES).

3D motion detection and a new learning algorithm adapt to the changes in gait dynamics and activate stimulation within 0.01 seconds. The L300 Go controls the extent of dorsiflexion precisely with just a single electrode. A three-axis gyroscope and acceleration sensors monitor movement patterns in all three planes.

### Application

- Mild to moderate drop foot (dorsiflexor weakness) with no or only mild spasticity, stabilisation of valgus/varus deviations in the ankle joint

### Modes of action

The L300 Go stimulates the muscles of the affected leg with small electrical impulses so that dorsiflexion can be triggered. This not only improves the gait but also contributes to rebuilding the musculature or to delaying/preventing atrophy due to inactivity (amyotrophica). The L300 Go may also increase mobility in the joint and promote local circulation.





### Special features

- Fast, intuitive fitting by qualified personnel thanks to quick adaptation mode and Bluetooth programming
- 3D motion detection for monitoring all three planes
- Optional foot sensor and remote control
- Analysis of results with an integrated 10-m walking test



28FS300 L300 Go

### 28FS300 L300 Go

Lower leg cuff, small	Size	cm
	XXS	22–26
	XS	25–31

## Spare parts for 28FS300 L300 Go

### Small quick fit electrode A

Article number	Unit
28FS300S=LG3-6800	Piece(s)

### Small quick fit electrode B

Article number	Unit
28FS300S=LG3-6900	Piece(s)

### Small round textile electrode, 36 mm

Article number	Unit
28FS300S=LG3-6600	Piece(s)

### Small hydrogel electrode, 36 mm

Article number	Unit
28FS300S=LG3-6700	Piece(s)

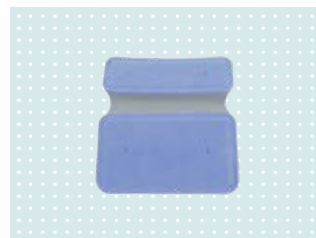

28FS300S=LG3-6800



28FS300S=LG3-6900



28FS300S=LG3-6600

# Functional electrical stimulation

## Spare parts for 28FS300 L300 Go

### Small electrode adapter set

(for hydrogel & textile), 36 mm

Article number	Unit
28FS300S=LG3-6500	Piece(s)

### Cable cover (for adapter sets)

Article number	Unit
28FS300S=LG3-5L00	Piece(s)

### Lower leg cuff, right, small

Article number	Unit
28FS300S=LG4-6200	Piece(s)

### Lower leg cuff, left, small

Article number	Unit
28FS300S=LG4-6100	Piece(s)

### Lower leg strap, XS (small cuff)

Article number	Unit
28FS300S=LG4-6300	Piece(s)

### Lower leg strap, XXS (small cuff)

Article number	Unit
28FS300S=LG4-6400	Piece(s)

### Magnetic charging cable

Article number	Unit
28FS300S=LG4-7100	Piece(s)

### System charger with charging adapters

Article number	Unit
28FS300S=LG4-7200	Piece(s)

### Battery for foot sensor/remote control

Article number	Unit
28FS300S=LG4-5R00	Piece(s)

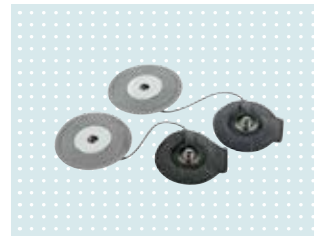

28FS300S=LG3-6500



28FS300S=LG4-6200  
28FS300S=LG4-6100



28FS300S=LG4-6300  
28FS300S=LG4-6400



28FS300S=LG4-7100



28FS300S=LG4-7200



## Accessories for 28FS300 L300 Go

### Foot sensor, standard

Article number	Unit
28FS300A=LG4-5400	Piece(s)

### Foot sensor, long

Article number	Unit
28FS300A=LG4-5500	Piece(s)

### Adhesive pads for foot sensor (2 pieces)

Article number	Unit
28FS300A=LG3-5K00	Piece(s)

### Inlays, right, small (10 pieces)

Article number	Unit
28FS300S=LG3-6A10	Piece(s)

### Inlays, left, small (10 pieces)

Article number	Unit
28FS300S=LG3-6B10	Piece(s)

### Remote control

Article number	Unit
28FS300A=LG4-5200	Piece(s)

### Remote control, protective cover

Article number	Unit
28FS300A=LG4-5201	Piece(s)

### Remote control, neck strap

Article number	Unit
28FS300S=20-0005	Piece(s)

### Stimulation tester

Article number	Unit
28FS300S=20-0004	Piece(s)

### Fitting cable

Article number	Unit
28FS300S=LG3-4900	Piece(s)

### Bluetooth dongle

Article number	Unit
28FS300S=LG4-BT01	Piece(s)

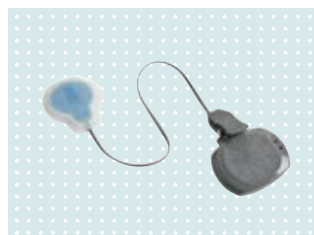

▶ 28FS300A=LG4-5400  
▶ 28FS300A=LG4-5500



▶ 28FS300A=LG3-5K00



▶ 28FS300S=LG3-6A10  
▶ 28FS300S=LG3-6B10



▶ 28FS300A=LG4-5200



▶ 28FS300S=20-0005



▶ 28FS300S=20-0004



▶ 28FS300S=LG3-4900

# AFO – Flexible ankle joints

---

## 17AF10 X-ible

It's so fle[X-ible]!



The 17AF10 is a self-aligning, flexible joint with a free motion or dorsal support function. Its different versions enable the 17AF10 to be adapted to the user's individual needs. The lightweight, flat design makes the 17AF10 particularly attractive and the fabrication of thermoplastic orthoses especially efficient.

- The user's activity level and functional requirements are the key factors for determining the correct joint size
- Gait analysis and muscle status are the key factors for determining the correct degree of hardness

### **Our recommendation**

Use antibacterial thermoplastic synthetic materials, e.g. 616T120 ThermoLyn PPC SilverShield® and 623S\* thermopaper (available in various designs).



## 17AF10 X-ible

Stabilisation of the ankle joint in the frontal plane

Article number	Size	Length	Unit
17AF10=S	S	3.2 cm	2
17AF10=M	M	3.8 cm	2
17AF10=L	L	4.5 cm	2

## 17AF10 X-ible

Pre-flexed to support dorsiflexion in the sagittal plane

Article number	Size	Length	Grade of hardness	Nm	Unit
17AF10=S-DA-LT	S	3.2 cm	75	0.5	2
17AF10=S-DA-MD	S	3.2 cm	85	0.75	2
17AF10=S-DA-ST	S	3.2 cm	95	1	2
17AF10=M-DA-LT	M	3.8 cm	75	2	2
17AF10=M-DA-MD	M	3.8 cm	85	2.5	2
17AF10=M-DA-ST	M	3.8 cm	95	4	2
17AF10=L-DA-LT	L	4.5 cm	75	3.4	2
17AF10=L-DA-MD	L	4.5 cm	85	4.3	2
17AF10=L-DA-ST	L	4.5 cm	95	6.2	2

## Accessories

### 17AF10A X-ible dummy

Article number	For	Unit
17AF10A=DY-S	17AF10=S	2
	17AF10=S-DA-LT	
	17AF10=S-DA-MD	
	17AF10=S-DA-ST	
17AF10A=DY-M	17AF10=M	2
	17AF10=M-DA-LT	
	17AF10=M-DA-MD	
17AF10A=DY-L	17AF10=L	2
	17AF10=L-DA-LT	
	17AF10=L-DA-MD	
	17AF10=L-DA-ST	



17AF10 X-ible

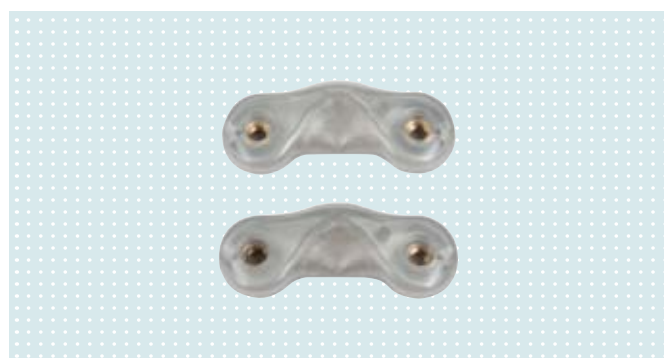

17AF10 X-ible pre-flexed



17AF10A X-ible Dummy

# AFO – Conventional ankle joints

---

## 17AD1/17AF2 Conventional ankle joints for thermoplastic technique



### **Effortlessly variable support**

The ankle joints for thermoplastic ankle-foot orthoses offer numerous possibilities for fabricating lightweight, functional orthoses for children. Whether free-moving ankle joints for movement guidance or ankle joints that offer the option of controlling or supporting movements, these joints are suitable for numerous indications. The 17AD1 and 17AF2 ankle joints are practice-oriented, making them easy to work with during production and also simple to use from a functional perspective.

### 17AD1

Dual-function ankle joints with stop pins or springs to limit or support plantar flexion and dorsal extension. Indication: e.g. ICP.

For integrating into ankle-foot orthoses with dorsal, plantar limitation or spring assist, including parallel alignment aid.

Article number	Max. body weight	Material	Max. lower leg length	Overall length of upper section – foot stirrup	Version	Unit
17AD1=120	100 kg	Stainless steel	550 mm	120 mm	Adults	Set
17AD1=93	35 kg	Stainless steel	350 mm	93 mm	Children	Set



17AD1

### 17AF2

Free motion ankle joints. Maintenance-free, supported joints that do not permit limitation in the A-P direction but are stable in the M-L direction. Indication: e.g. severe ankle instabilities.

All joints are supplied with a parallel truing tube and corresponding screws for installation.

Article number	Material	Overall length of upper section – foot stirrup	Version	Unit
17AF2=77	Stainless steel	77.5 mm	Adults	Set
17AF2=63	Stainless steel	63.5 mm	Children	Set



17AF2

- A simple tool for parallel adjustment is included in the delivery
- Scope of delivery – see illustration



# AFO – Free motion ankle joints

## 17F34/17F24 Ankle joint bar for children



### Forged foot stirrup, flat bar profile, fixed joint, upper sections and foot stirrup

Article number	Bar length/width/thickness	Stirrup length from joint centre	Stirrup width	Head diameter	Material	Unit
17F34=6	180/12/2 mm	115 mm	25 mm	16 mm	Stainless steel	Pair
17F34=5	240/14/2 mm	130 mm	30 mm	18 mm	Stainless steel	Pair

### Forged foot stirrup, fixed joint, upper sections and foot stirrup

Article number	Bar length/width/thickness	Stirrup length from joint centre	Stirrup width	Head diameter	Material	Unit
17F24=5	300/15/3 mm	130 mm	40 mm	20 mm	Stainless steel	Pair
17F24=4	300/15/3 mm	130 mm	40 mm	22 mm	Stainless steel	Pair
17F24=2	390/18/3 mm	150 mm	40 mm	24 mm	Stainless steel	Pair

The ankle joint bars for children have been a permanent part of proven fittings with AFO or KAFO solutions for years. Unlike other systems, the foot stirrups and joint bars are designed for high stability. This helps achieve a high correction effect for the entire orthosis. The joint, which is referred to as free motion, has to be adapted by the O&P professional according to the treatment requirements. The benefit is that the O&P professional can make changes in the position and range of motion without any further assistance.

The ankle joint bar is freely moveable. A +/- 30° range of motion can be established by filing the upper section.



## 17CF1 Carbon Ankle seven

Dynamics without compromises

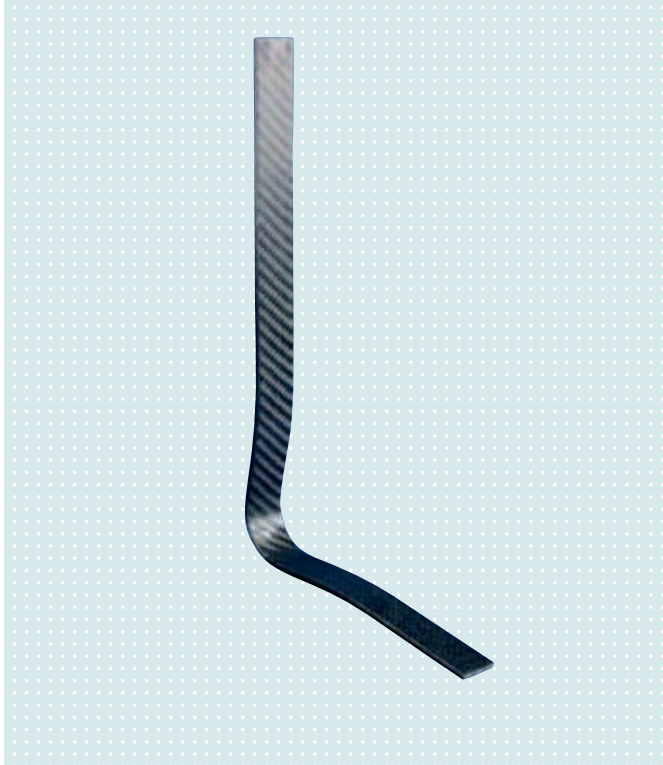

### How it works

The carbon springs are designed to initiate extension moments of the hip and knee during walking. This achieves extension and knee stability in the lower limbs. The energy generated during heel strike is stored in the carbon matrix and released again at toe-off. In contrast to conventional ankle-foot orthoses, the limits in the plantar and dorsal directions are dynamic and without static restriction.

### Application

Paralysis or weakness/restriction

- of the foot lifting and foot lowering muscles while using a dynamic ankle-foot orthosis (DAFO)
- of the knee extensors while using a knee ankle-foot orthosis (KAFO) with locked knee joint; typical underlying diseases include e.g. spina bifida or polio

### Special features

- Positive influence on the gait pattern
- Very lightweight design
- 7° outward rotation supports physiological alignment of the foot
- Classification makes it easy to select the right product
- Suitable for thermoplastic and laminated orthoses



# AFO – Dynamic components



## Selecting and ordering

The Carbon Ankle seven is selected on the basis of the user's body weight and activity level.

- Normal activity level: a normally active user performs all activities of daily life independently and carries out relatively simple tasks.
- High activity level: this user has no restrictions in everyday life. Orthoses for highly active users must support quick changes from walking to running and vice versa, e.g., for individuals who play sports or for children.



Article number	Max. body weight (normal activity level)	Max. body weight (high activity level)	Spring width	Unit
17CF1=L/R1	100 kg	100 kg	30 mm	Piece(s)
17CF1=L/R2	90 kg	80 kg	30 mm	Piece(s)
17CF1=L/R3	80 kg	70 kg	30 mm	Piece(s)
17CF1=L/R4	70 kg	60 kg	30 mm	Piece(s)
17CF1=L/R5	60 kg	50 kg	30 mm	Piece(s)
17CF1=L/R6	50 kg	–	25/30 mm	Piece(s)
17CF1=L/R7	–	40 kg	25 mm	Piece(s)
17CF1=L/R8	40 kg	30 kg	25 mm	Piece(s)
17CF1=L/R9	30 kg	–	25 mm	Piece(s)
17CF1=L/R10	–	20 kg	25 mm	Piece(s)
17CF1=L/R11	20 kg	10 kg	22 mm	Piece(s)
17CF1=L/R12	10 kg	–	22 mm	Piece(s)

---

## Single components for 17CF1

### Rosette washer

Article number	Unit
507U9=M5	Piece(s)
507U9=M4	Piece(s)

### Phillips oval countersunk head screw

Article number	Unit
507U9=M5	Piece(s)
507U9=M4	Piece(s)

### Welding nut

Article number	Unit
502E3=M5x7.5	Piece(s)
502E3=M4x6	Piece(s)

### Classification of the Carbon Ankle seven for AFOs

You can easily find the correct article number in the classification matrix shown at left. Simply select the side (e.g. 17CF1=L9 for the left side for a normally active patient who weighs up to 30 kg).

The delivery includes detailed mounting instructions as well as the attachment material needed for the integration into an orthosis.

- ▶ The classification applies to AFOs that are intended to influence the knee joint
- ▶ The use of the Carbon Ankle seven carbon spring for KAFOs may require a deviation from the classification
- ▶ The specified weights refer to functionality rather than durability

# AFO – Multifunctional ankle joint

---

## 17LA3N Unilateral ankle joint

Small, lightweight and versatile



The 17LA3N unilateral ankle joint is a multifunctional system ankle joint with a dorsiflexion effect. Various combination possibilities allow it to be quickly adjusted to the individual user's needs at any time. Its weight classification permits unilateral use for a patient weight of up to 110 kg and bilateral use for up to 160 kg. Despite its multifunctional features it is small, lightweight and inconspicuous – truly versatile.

### Application

Partial or total paralysis of the leg muscles. Indications must be determined by the physician.

### Special features

- Integrated joint system in five sizes, suitable for both children and adults
- Damped stop for significant noise reduction
- Reduced weight due to lightweight construction
- Can be used for prepreg and lamination resin techniques
- Temporary switch for releasing the joint, e.g. for training on a therapy bike, included in the scope of delivery
- Weight classification for unilateral and bilateral makes it easier to select the joint size
- Lamination/prepreg dummy included in the scope of delivery
- Titanium or steel versions
- Improved ease of service
- Exclusive use of TORX® screws

Article number	System width	Max. body weight	Material	Unit
17LA3N=10	10 mm	15 kg (unilateral) / 25 kg (bilateral)	Steel	Piece(s)
17LA3N=10-T	10 mm	15 kg (unilateral) / 25 kg (bilateral)	Titanium	Piece(s)
17LA3=12	12 mm	20 kg (unilateral) / 40 kg (bilateral)	Steel	Piece(s)
17LA3=12-T	12 mm	20 kg (unilateral) / 40 kg (bilateral)	Titanium	Piece(s)
17LA3=14	14 mm	50 kg (unilateral) / 80 kg (bilateral)	Steel	Piece(s)
17LA3=14-T	14 mm	50 kg (unilateral) / 80 kg (bilateral)	Titanium	Piece(s)
17LA3=16	16 mm	85 kg (unilateral) / 120 kg (bilateral)	Steel	Piece(s)
17LA3=16-T	16 mm	85 kg (unilateral) / 120 kg (bilateral)	Titanium	Piece(s)
17LA3=20	20 mm	110 kg (unilateral) / 160 kg (bilateral)	Steel	Piece(s)
17LA3=20-T	20 mm	110 kg (unilateral) / 160 kg (bilateral)	Titanium	Piece(s)



► 17LA3N unilateral ankle joint

- The next higher size must be used when using the product unilaterally and in case of flexion contractures in the knee or hip  $> 10^\circ$ , distinct torsion or valgus/varus instabilities or increased physical activity
- The product must be fitted bilaterally for ischial support or valgus/varus malpositions greater than  $10^\circ$



# AFO – Multifunctional ankle joint

## Accessories

### 17LF3N Foot stirrup for unilateral ankle joints

Free motion foot stirrup with up to 20° plantar flexion and dorsal extension. Only in combination with the 17LA3N=\* ankle joint.

Article number	For	Material	Unit
17LF3N=10	17LA3N=10	Stainless steel	Piece(s)
17LF3N=12	17LA3N=12	Stainless steel	Piece(s)
17LF3N=14	17LA3N=14	Stainless steel	Piece(s)
17LF3N=16	17LA3N=16	Stainless steel	Piece(s)
17LF3N=20	17LA3N=20	Stainless steel	Piece(s)



17LF3N foot stirrup

### 17LS3 Lamination bar for unilateral joint system

Article number	Length	Width	Material	Unit
17LS3=10	80 mm	10 mm	Stainless steel	Piece(s)
17LS3=10-T	80 mm	10 mm	Titanium	Piece(s)
17LS3=12	80 mm	12 mm	Stainless steel	Piece(s)
17LS3=12-T	80 mm	12 mm	Titanium	Piece(s)
17LS3=14	100 mm	14 mm	Stainless steel	Piece(s)
17LS3=14-T	100 mm	14 mm	Titanium	Piece(s)
17LS3=16	130 mm	16 mm	Stainless steel	Piece(s)
17LS3=16-T	130 mm	16 mm	Titanium	Piece(s)
17LS3=20	130 mm	20 mm	Stainless steel	Piece(s)
17LS3=20-T	130 mm	20 mm	Titanium	Piece(s)

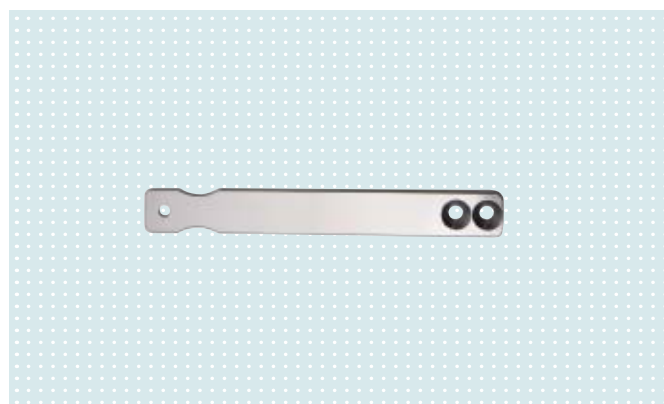

17LS3 lamination bar





### 17LD1N Lamination dummy for unilateral ankle joint incl. shoulder screw

Article number	For	Material	Unit
17LD1N=10	17LA3N=10	Stainless steel	Piece(s)
17LD1N=12	17LA3N=12	Stainless steel	Piece(s)
17LD1N=14	17LA3N=14	Stainless steel	Piece(s)
17LD1N=16	17LA3N=16	Stainless steel	Piece(s)
17LD1N=20	17LA3N=20	Stainless steel	Piece(s)



17LD1N lamination dummy

### 17LV3 Side bar

Article number	Width	Material	Unit
17LV3=10	10 mm	Stainless steel	Piece(s)
17LV3=12	12 mm	Stainless steel	Piece(s)
17LV3=14	14 mm	Stainless steel	Piece(s)
17LV3=16	16 mm	Stainless steel	Piece(s)
17LV3=20	12 mm	Stainless steel	Piece(s)

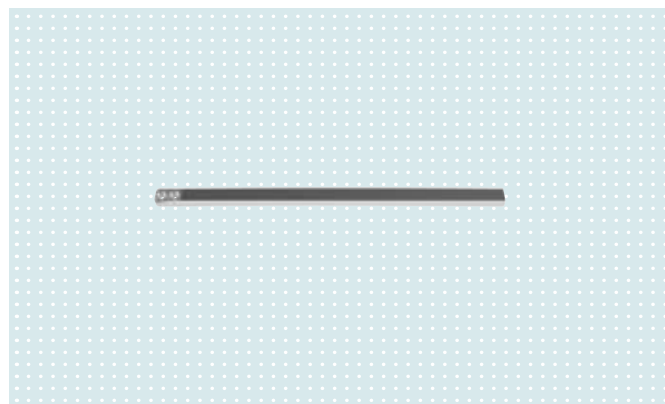

17LV3 side bar

### 702B11 Drilling fixture

Article number	Material	To be used for
702B11	Tool steel	17LV3

# AFO – Multifunctional ankle joint

---

## 17AD100 Nexgear Tango ankle joint

Strong. Dynamic. Modular.



This modular system offers the necessary dynamics for a more efficient and physiological gait. The functional modules make it possible to adapt the function and design to the individual needs of the user, and they can be upgraded or downgraded at any time. This allows the joint to be flexibly adapted, for example during rehabilitation. The central element is the Reaction-module, which dynamically controls and supports dorsiflexion and plantar flexion of the foot and influences the knee in the stance phase – different Reaction-Springs are available for this. This means that the necessary energy return can be optimised individually for a significantly more dynamic gait. In addition, the Nexgear Tango ensures a large range of motion in the ankle, even with a high spring force.

Its weight classification permits unilateral use for a patient weight of up to 110 kg and bilateral use for up to 160 kg. The Nexgear Tango is available in adult and children's sizes, and in steel and titanium.

### **Application**

Partial or total paralysis of the leg muscles, mainly in case of neurological diseases such as:

- Incomplete spinal cord injury (ISC)
- Traumatic brain injury
- Infantile cerebral palsy
- Stroke

Indications must be determined by the physician.

### Special features

- The double action ankle joint with three function modules (Stop-module, Spring-module, Reaction-module) ensures optimal adaptation to the user's needs in terms of function and design
- Individual adaptability throughout the entire rehabilitation process thanks to modules that can be added and removed
- Reaction-module:
  - High level of energy return with maximum freedom of movement in the ankle
  - Dynamic control of plantar flexion and dorsiflexion, support for knee extension in the mid-stance phase and support during toe-off/initiation of the swing phase
  - Separate static and dynamic alignment
  - Dynamic adjustment thanks to continuously variable pretension
  - Two Reaction-Springs in the strong and extra strong versions
- For adults and children, selected by weight classification
- For unilateral and bilateral fittings
- Base body available in titanium and steel

### Modular design

The modules that are to be used with the base body must be selected according to the individual needs. There are three different modules: Stop-module, Spring-module and Reaction-module.

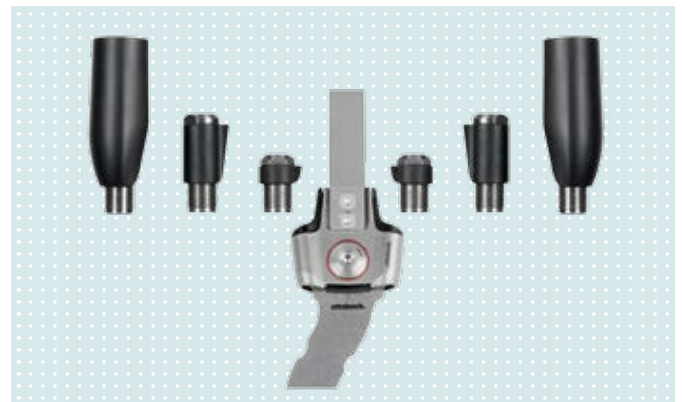

• Base body with Stop-module, Spring-module and Reaction-module

### 17AD100=\* Base body

Article number	System width	Max. body weight	Material	ME
17AD100=10	10 mm	15 kg (unilateral) / 25 kg (bilateral)	Steel	Piece(s)
17AD100=10-T	10 mm	15 kg (unilateral) / 25 kg (bilateral)	Titanium	Piece(s)
17AD100=12	12 mm	20 kg (unilateral) / 40 kg (bilateral)	Steel	Piece(s)
17AD100=12-T	12 mm	20 kg (unilateral) / 40 kg (bilateral)	Titanium	Piece(s)
17AD100=14	14 mm	50 kg (unilateral) / 80 kg (bilateral)	Steel	Piece(s)
17AD100=14-T	14 mm	85 kg (unilateral) / 120 kg (bilateral)	Titanium	Piece(s)
17AD100=16	16 mm	85 kg (unilateral) / 120 kg (bilateral)	Steel	Piece(s)
17AD100=16-T	16 mm	85 kg (unilateral) / 120 kg (bilateral)	Titanium	Piece(s)
17AD100=20	20 mm	110 kg (unilateral) / 160 kg (bilateral)	Steel	Piece(s)
17AD100=20-T	20 mm	110 kg (unilateral) / 160 kg (bilateral)	Titanium	Piece(s)



• 17AD100=\* base body

# AFO – Multifunctional ankle joint

## 17AD100A=AS\* Stop-module

The 17AD100A=AS\* Stop-module for the adjustable stop can be used to set a continuously variable dorsal or plantar stop.

Article number	System width	Max. body weight	Unit
17AD100A=AS-10	10 mm	15 kg (unilateral) / 25 kg (bilateral)	Piece(s)
17AD100A=AS-12	12 mm	20 kg (unilateral) / 40 kg (bilateral)	Piece(s)
17AD100A=AS-14	14 mm	50 kg (unilateral) / 80 kg (bilateral)	Piece(s)
17AD100A=AS-16	16 mm	85 kg (unilateral) / 120 kg (bilateral)	Piece(s)
17AD100A=AS-20	20 mm	110 kg (unilateral) / 160 kg (bilateral)	Piece(s)



17AD100A=AS\* Stop-module

## 17AD100A=LS\* Spring-module

The 17AD100A=LS\* Spring-module has a continuously variable compression spring for adjusting the dorsal support.

Article number	System width	Max. body weight	Unit
17AD100A=LS-10	10 mm	15 kg (unilateral) / 25 kg (bilateral)	Piece(s)
17AD100A=LS-12	12 mm	20 kg (unilateral) / 40 kg (bilateral)	Piece(s)
17AD100A=LS-14	14 mm	50 kg (unilateral) / 80 kg (bilateral)	Piece(s)
17AD100A=LS-16	16 mm	85 kg (unilateral) / 120 kg (bilateral)	Piece(s)
17AD100A=LS-20	20 mm	110 kg (unilateral) / 160 kg (bilateral)	Piece(s)



17AD100A=LS\* Spring-module



### 17AD100A=HS\* Reaction-module

The Reaction-module features very high spring forces. In addition to damped and controlled plantar flexion, this module therefore offers dynamic control of the knee in the mid-stance phase and a high level of energy return at the beginning of the swing phase.

Article number	System width	Max. body weight	Unit
17AD100A=HS-10	10 mm	15 kg (unilateral) / 25 kg (bilateral)	Piece(s)
17AD100A=HS-12	12 mm	20 kg (unilateral) / 40 kg (bilateral)	Piece(s)
17AD100A=HS-14	14 mm	50 kg (unilateral) / 80 kg (bilateral)	Piece(s)
17AD100A=HS-16	16 mm	85 kg (unilateral) / 120 kg (bilateral)	Piece(s)
17AD100A=HS-20	20 mm	110 kg (unilateral) / 160 kg (bilateral)	Piece(s)

### Reaction-Spring

The central element of the Reaction-module is the Reaction-Spring, which is available in two different strengths (strong, extra strong). Choose the corresponding spring according to the individual spring force required.

Article number		For	Unit
17AD100A=HS-12-1	Strong	17AD100A=HS-10 17AD100A=HS-12	Piece(s)
17AD100A=HS-14-1	Strong	17AD100A=HS-14	Piece(s)
17AD100A=HS-20-1	Strong	17AD100A=HS-16 17AD100A=HS-20	Piece(s)

Article number		For	Unit
17AD100A=HS-12-2	Extra strong	17AD100A=HS-10 17AD100A=HS-12	Piece(s)
17AD100A=HS-14-2	Extra strong	17AD100A=HS-14	Piece(s)
17AD100A=HS-20-2	Extra strong	17AD100A=HS-16 17AD100A=HS-20	Piece(s)

The Reaction-Springs must be ordered separately for each Reaction-module.



17AD100A=HS\* Reaction-module



17AD100A=HS\* Reaction-Spring, strong



17AD100A=HS\* Reaction-Spring, extra strong



# AFO – Multifunctional ankle joint

## Accessories

### 17AD100A=DY\* Dummy

Article number	For	Unit
17AD100A=DY-10	17AD100=10 17AD100=10-T	Piece(s)
17AD100A=DY-12	17AD100=12 17AD100=12-T	Piece(s)
17AD100A=DY-14	17AD100=14 17AD100=14-T	Piece(s)
17AD100A=DY-16	17AD100=16 17AD100=16-T	Piece(s)
17AD100A=DY-20	17AD100=20 17AD100=20-T	Piece(s)

The 17AD100A=DY\*-P plastic cover is included with the 17AD100 base body.

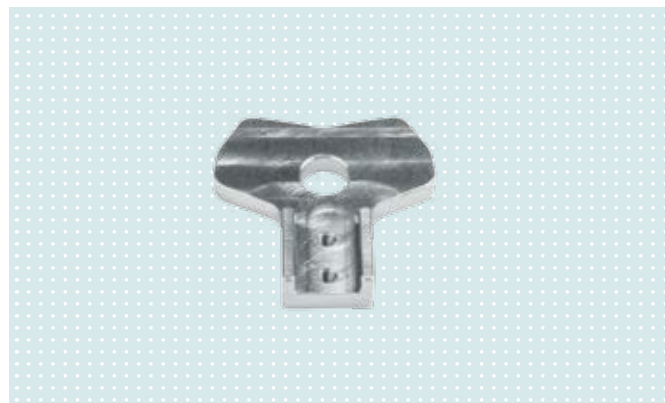

17AD100=DY\* dummy

### 17SF100=OS\* Foot stirrup

Article number	For	Unit
17SF100=OS-10	17AD100=10 17AD100=10-T	Piece(s)
17SF100=OS-12	17AD100=12 17AD100=12-T	Piece(s)
17SF100=OS-14	17AD100=14 17AD100=14-T	Piece(s)
17SF100=OS-16	17AD100=16 17AD100=16-T	Piece(s)
17SF100=OS-20	17AD100=20 17AD100=20-T	Piece(s)

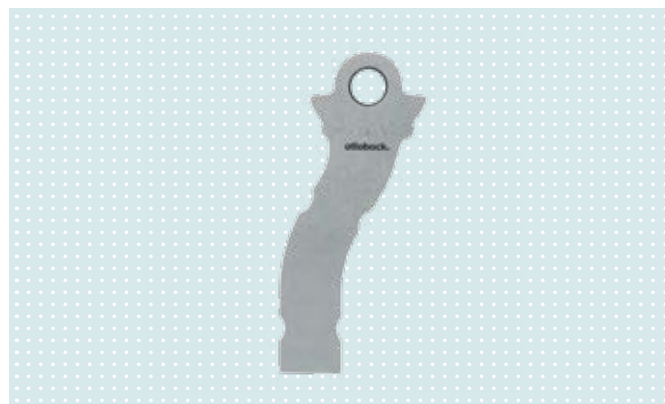

17SF100=OS\* foot stirrup



### 17LS3=\* Lamination bar

Article number	Length	Width	Material	Unit
17LS3=10	80 mm	10 mm	Steel	Piece(s)
17LS3=10-T	80 mm	10 mm	Titanium	Piece(s)
17LS3=12	80 mm	12 mm	Steel	Piece(s)
17LS3=12-T	80 mm	12 mm	Titanium	Piece(s)
17LS3=14	100 mm	14 mm	Steel	Piece(s)
17LS3=14-T	100 mm	14 mm	Titanium	Piece(s)
17LS3=16	130 mm	16 mm	Steel	Piece(s)
17LS3=16-T	130 mm	16 mm	Titanium	Piece(s)
17LS3=20	130 mm	20 mm	Steel	Piece(s)
17LS3=20-T	130 mm	20 mm	Titanium	Piece(s)

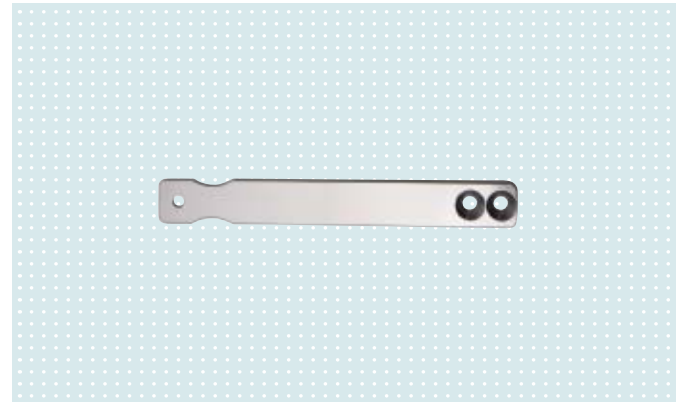

17LS3=\* lamination bar

### 17AD100=MA\* Mounting adapter

For installing and removing all three function modules.

Article number	For	Unit
17AD100A=MA-10	17AD100A=HS-10 17AD100A=LS-10 17AD100A=AS-10	Piece(s)
17AD100A=MA-12	17AD100A=HS-12 17AD100A=LS-12 17AD100A=AS-12	Piece(s)
17AD100A=MA-14	17AD100A=HS-14 17AD100A=LS-14 17AD100A=AS-14	Piece(s)
17AD100A=MA-16	17AD100A=HS-16 17AD100A=LS-16 17AD100A=AS-16	Piece(s)
17AD100A=MA-20	17AD100A=HS-16 17AD100A=LS-16 17AD100A=AS-16 17AD100A=HS-20 17AD100A=LS-20 17AD100A=AS-20	Piece(s)



17AD100=MA\* mounting adapter

# AFO – Multifunctional ankle joint

## Accessories

### 709S530 TORX® key set

<b>Article number</b>	<b>709S530</b>
<b>For</b>	TORX® socket screws
<b>Scope of delivery</b>	Nine-piece set: <ul style="list-style-type: none"><li>• Without ball head on the long arm: 1x TX 8x76; 1x TX 9x79; 1x TX 10x85</li><li>• With ball head on the long arm: 1x TX 15x90; 1x TX 20x96; 1x TX 25x104; 1x TX 27x112; 1x TX 30x122; 1x TX 40x132</li></ul>
<b>Version</b>	TORX® on the short arm, TORX® ball head on the long arm

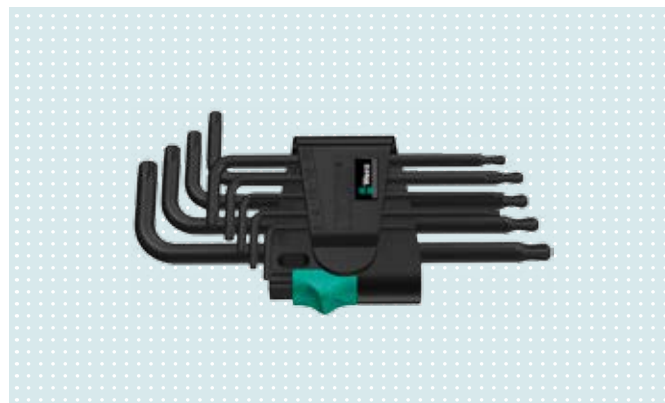

709S530 TORX® key set

### 710D20 Torque wrench 1–25 Nm

<b>Article number</b>	<b>710D20</b>
<b>Version</b>	1/4" square drive
<b>Equipment</b>	Adjustable and readable torque value, includes calibration certificate
<b>Measurement range</b>	1–25 Nm
<b>Overall wrench length</b>	291 mm
<b>Scope of delivery</b>	Without hexagon bits



710D20 torque wrench

## 710Y19 Connecting element

<b>Article number</b>	<b>710Y19</b>
<b>For</b>	1/4" hexagon bits according to DIN ISO 1173-C 6.3 and E 6.3
<b>To be used for</b>	710D20 torque wrench
<b>Version</b>	Quick-release chuck for changing bits quickly, chrome-vanadium



710Y19 Connecting element

## 710Y25 TORX® bit extension

<b>Article number</b>	<b>710Y25</b>
<b>For</b>	TORX® socket screws
<b>To be used for</b>	710D20 torque wrench
<b>Version</b>	With extended TORX® profile behind the ball head; TORX® ball head enables screwing at an angle of up to 25°



710Y25 TORX® bit extension



# AFO – Multifunctional ankle joint

## Service sets

### For 17AD100=\* Base body

#### 17AD100S=\* Base body and axial washers

Article number	Description	For	Consisting of
17AD100S=10		17AD100=10 17AD100=10-T	
17AD100S=12		17AD100=12 17AD100=12-T	
17AD100S=14	Service set for base body	17AD100=14 17AD100=14-T	1x joint nut (1) 1x joint screw (2)
17AD100S=16		17AD100=16 17AD100=16-T	
17AD100S=20		17AD100=20 17AD100=20-T	
17AD100S=10-1		17AD100=10 17AD100=10-T	
17AD100S=12-1		17AD100=12 17AD100=12-T	
17AD100S=14-1	Service set axial washers	17AD100=14 17AD100=14-T	10x axial washer (3)
17AD100S=16-1		17AD100=16 17AD100=16-T	
17AD100S=20-1		17AD100=20 17AD100=20-T	

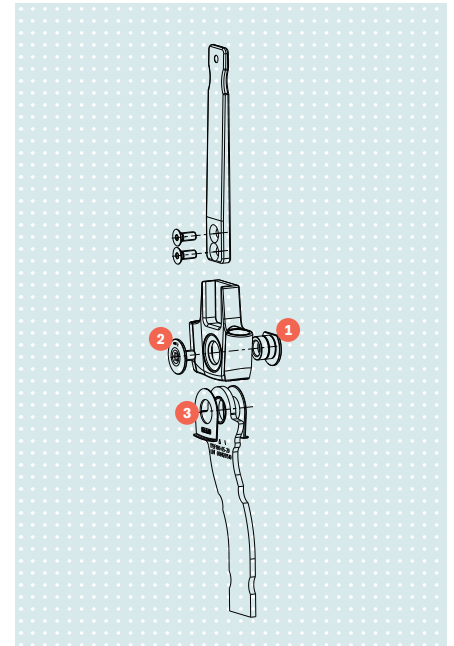

### For 17AD100A=AS\* Stop-module

#### 17AD100S=AS\* Stop and cover

Article number	Description	For	Consisting of
17AD100S=AS-10-1		17AD100A=AS-10	
17AD100S=AS-12-1		17AD100A=AS-12	
17AD100S=AS-14-1	Service set for Stop-module	17AD100A=AS-14	1x stop (1)
17AD100S=AS-16-1		17AD100A=AS-16	
17AD100S=AS-20-1		17AD100A=AS-20	
17AD100S=AS-10-2		17AD100A=AS-10	
17AD100S=AS-12-2		17AD100A=AS-12	
17AD100S=AS-14-2	Cover for Stop-module	17AD100A=AS-14	1x cover (2)
17AD100S=AS-16-2		17AD100A=AS-16	
17AD100S=AS-20-2		17AD100A=AS-20	

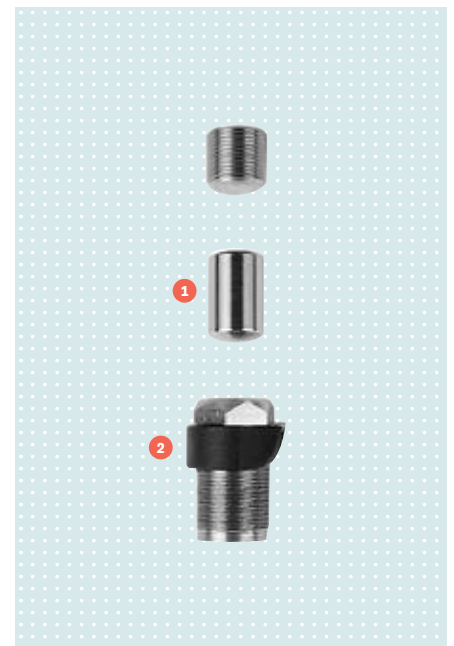



## For 17AD100A=LS\* Spring-module

### 17AD100S=LS\* Spring and cover

Article number	Description	For	Consisting of
17AD100S=LS-10-1	Service set for Spring-module	17AD100A=LS-10	1x compression spring (1) 1x plastic sleeve (2) 1x ball (3)
17AD100S=LS-12-1		17AD100A=LS-12	
17AD100S=LS-14-1		17AD100A=LS-14	
17AD100S=LS-16-1		17AD100A=LS-16	
17AD100S=LS-20-1		17AD100A=LS-20	
17A100S=LS-10-2	Cover for Spring-module	17A100A=LS-10	1x cover (4)
17A100S=LS-12-2		17A100A=LS-12	
17A100S=LS-14-2		17A100A=LS-14	
17A100S=LS-16-2		17A100A=LS-16	
17A100S=LS-20-2		17A100A=LS-20	

### 30Y309=\* Set screw

Article number	Description	For	Consisting of
30Y309=10	Set screw	17AD100A=LS-10	1x set screw (5)
30Y309=12		17AD100A=LS-12	
30Y309=14		17AD100A=LS-14	
30Y309=20		17AD100A=LS-16 17AD100A=LS-20	

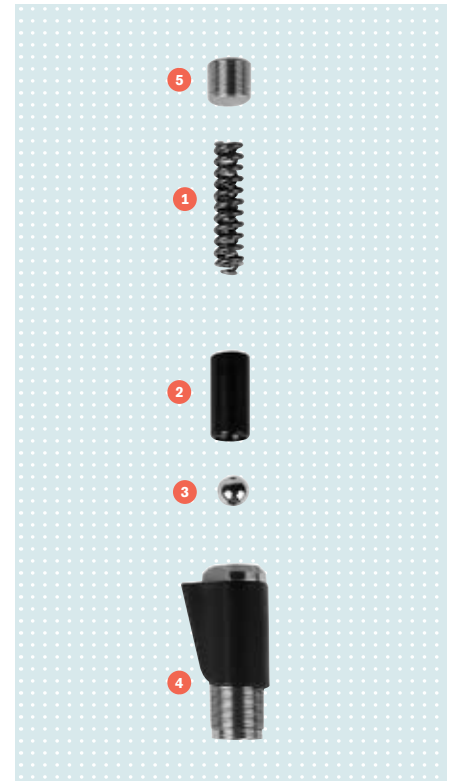

# AFO – Multifunctional ankle joint

## Service sets

### For 17AD100A=HS\* Reaction-module

#### 17AD100S=HS\* Reaction-module and cover

Article number	Description	For	Consisting of
17AD100S=HS-10-1		17AD100A=HS-10	
17AD100S=HS-12-1		17AD100A=HS-12	
17AD100S=HS-14-1	Service set for Reaction-module	17AD100A=HS-14	1x stop (1)
17AD100S=HS-16-1		17AD100A=HS-16	1x plastic sleeve (2)
17AD100S=HS-20-1		17AD100A=HS-20	
17AD100S=HS-10-2		17AD100A=HS-10	
17AD100S=HS-12-2		17AD100A=HS-12	
17AD100S=HS-14-2	Cover for Reaction-module	17AD100A=HS-14	1x cover (3)
17AD100S=HS-16-2		17AD100A=HS-16	
17AD100S=HS-20-2		17AD100A=HS-20	

#### 30Y444=\* Support element

Article number	Description	For	Consisting of
30Y444=10		17AD100A=HS-10	
30Y444=12		17AD100A=HS-12	
30Y444=14	Support element	17AD100A=HS-14	1x support element (4)
30Y444=16		17AD100A=HS-16	
30Y444=20		17AD100A=HS-20	

#### 516K2=\* Cover cap

Article number	Description	For	Consisting of
516K2=25-7		17AD100A=HS-10	
	Cover cap for Reaction-module	17AD100A=HS-12	
		17AD100A=HS-14	1x cover cap (5)
516K2=30-7		17AD100A=HS-16	
		17AD100A=HS-20	

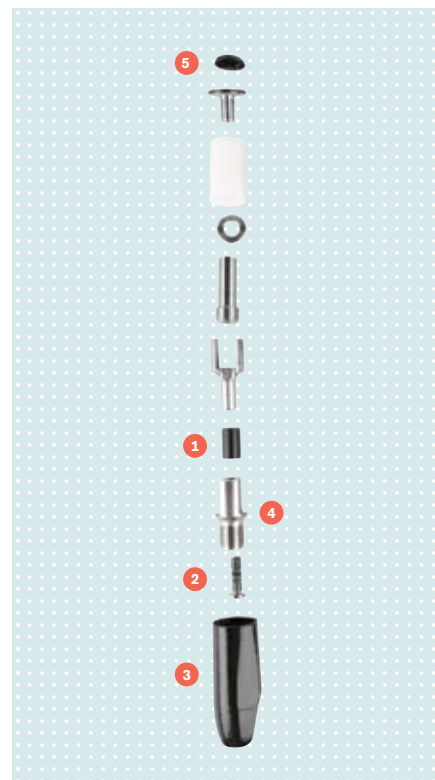

## For 17SF100=OS\* Foot stirrup

### 30Y306=\* Plastic bushing

Article number	Description	For	Consisting of
30Y306=10	Plastic bushing	17SF100=OS-10	1x plastic bushing (1)
30Y306=12		17SF100=OS-12	
30Y306=14		17SF100=OS-14	
30Y306=16		17SF100=OS-16	
30Y306=20		17SF100=OS-20	



## For 17AD100A=DY\* Dummy system

### 17AD100A=\* Dummy cover

Article number	Description	For	Consisting of
17AD100A=DY-10-P	Dummy cover	17AD100=10	1x dummy cover
17AD100A=DY-10-P		17AD100=10-T	
17AD100A=DY-10-P		17AD100=12	
17AD100A=DY-10-P		17AD100=12-T	
17AD100A=DY-10-P		17AD100=14	
17AD100A=DY-10-P		17AD100=14-T	
17AD100A=DY-10-P		17AD100=16	
17AD100A=DY-10-P		17AD100=16-T	
17AD100A=DY-10-P		17AD100=20	
17AD100A=DY-10-P		17AD100=20-T	



### 501F9=\* Dummy screw

Article number	Description	For	Consisting of
501F9=M4x20	Dummy screw	17AD100A=DY-10	1x screw
501F9=M4x20		17AD100A=DY-12	
501F9=M4x20		17AD100A=DY-14	
501F9=M4x20		17AD100A=DY-16	
501F9=M4x20		17AD100A=DY-20	

# KAFO/KO – System knee joint with wedge lock

---

## 17LK3 Unilateral knee joint

Lightweight and proven



The 17LK3 unilateral knee joint is a system knee joint with wedge lock. It is particularly attractive thanks to its lightweight construction. Its weight classification permits unilateral use for a body weight up to 110 kg and bilateral use for up to 160 kg. The system is suitable for prepreg and lamination resin techniques. The scope of delivery includes a temporary switch for releasing the joint (such as for training on a therapy bike).

### **Application**

Partial or total paralysis of the leg muscles. Indications must be determined by the physician.

### **Special features**

- Integrated joint system in four sizes, suitable for both children and adults
- Reduced weight due to lightweight construction
- Can be used for prepreg and lamination resin techniques
- Temporary switch for releasing the joint, e.g. for training on a therapy bike, included in the scope of delivery
- Weight classification for unilateral and bilateral use simplifies the selection of the joint size
- Lamination/prepreg dummy included in the scope of delivery
- Titanium or steel versions

## 17LK3 Unilateral knee joint

System knee joint with wedge lock

Article number	Side	System width	Max. body weight	Material	Unit
17LK3=L10	Left	10 mm	15 kg/25 kg*	Steel	Piece(s)
17LK3=L10-T	Left	10 mm	15 kg/25 kg*	Titanium	Piece(s)
17LK3=R10	Right	10 mm	15 kg/25 kg*	Steel	Piece(s)
17LK3=R10-T	Right	10 mm	15 kg/25 kg*	Titanium	Piece(s)
17LK3=L12	Left	12 mm	20 kg/40 kg*	Steel	Piece(s)
17LK3=L12-T	Left	12 mm	20 kg/40 kg*	Titanium	Piece(s)
17LK3=R12	Right	12 mm	20 kg/40 kg*	Steel	Piece(s)
17LK3=R12-T	Right	12 mm	20 kg/40 kg*	Titanium	Piece(s)
17LK3=L14	Left	14 mm	50 kg/80 kg*	Steel	Piece(s)
17LK3=L14-T	Left	14 mm	50 kg/80 kg*	Titanium	Piece(s)
17LK3=R14	Right	14 mm	50 kg/80 kg*	Steel	Piece(s)
17LK3=R14-T	Right	14 mm	50 kg/80 kg*	Titanium	Piece(s)
17LK3=L16	Left	16 mm	85 kg/120 kg*	Steel	Piece(s)
17LK3=L16-T	Left	16 mm	85 kg/120 kg*	Titanium	Piece(s)
17LK3=R16	Right	16 mm	85 kg/120 kg*	Steel	Piece(s)
17LK3=R16-T	Right	16 mm	85 kg/120 kg*	Titanium	Piece(s)
17LK3=L20	Left	20 mm	110 kg/160 kg*	Steel	Piece(s)
17LK3=L20-T	Left	20 mm	110 kg/160 kg*	Titanium	Piece(s)
17LK3=R20	Right	20 mm	110 kg/160 kg*	Steel	Piece(s)
17LK3=L20-T	Right	20 mm	110 kg/160 kg*	Titanium	Piece(s)

\* With bilateral use

- The next higher size must be used when using the product unilaterally and in cases of flexion contractures in the knee or hip > 10°, or distinct torsion or valgus/varus instabilities, or valgus/varus malpositions, or increased physical activity
- The product must be fitted bilaterally for ischial support

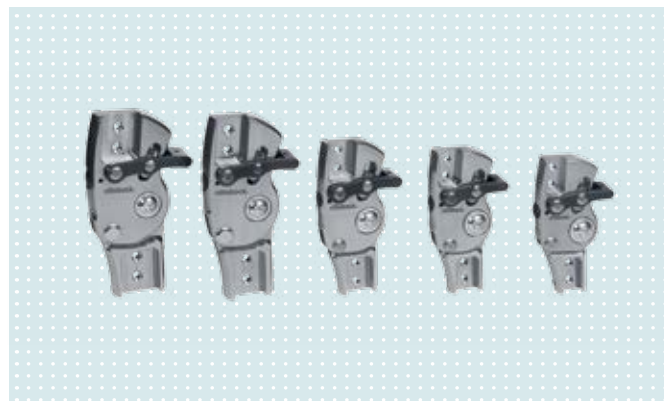

• 17LK3 in five different sizes

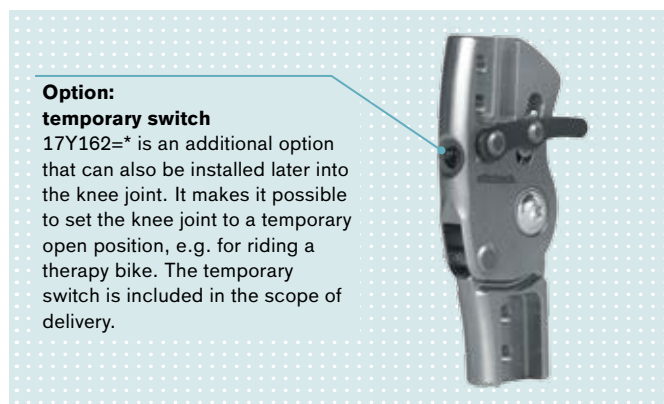

• 17Y162=\* temporary switch



# KAFO/KO – System knee joint with wedge lock

## Accessories

### 17LS3 Lamination bar

Article number	Length	Width	Thickness	Material	Unit
17LS3=10	80 mm	10 mm	5 mm bottom, 3 mm top	Stainless steel	Piece(s)
17LS3=10-T	80 mm	10 mm	5 mm bottom, 3 mm top	Titanium	Piece(s)
17LS3=12	80 mm	12 mm	5 mm bottom, 3 mm top	Stainless steel	Piece(s)
17LS3=12-T	80 mm	12 mm	5 mm bottom, 3 mm top	Titanium	Piece(s)
17LS3=14	100 mm	14 mm	6 mm bottom, 2.5 mm top	Stainless steel	Piece(s)
17LS3=14-T	100 mm	14 mm	6 mm bottom, 2.5 mm top	Titanium	Piece(s)
17LS3=16	130 mm	16 mm	6 mm bottom, 3 mm top	Stainless steel	Piece(s)
17LS3=16-T	130 mm	16 mm	6 mm bottom, 3 mm top	Titanium	Piece(s)
17LS3=20	130 mm	20 mm	6 mm bottom, 3 mm top	Stainless steel	Piece(s)
17LS3=20-T	130 mm	20 mm	6 mm bottom, 3 mm top	Titanium	Piece(s)

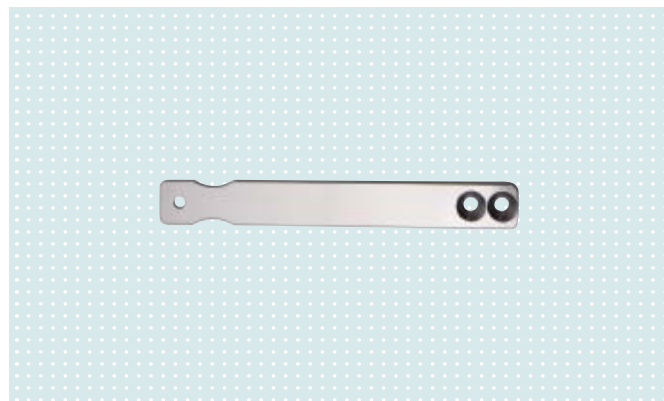

▶ 17LS3 lamination bar

### 17LV3 Side bar

Article number	Width	Material	Unit
17LV3=10	10 mm	Stainless steel	Piece(s)
17LV3=12	12 mm	Stainless steel	Piece(s)
17LV3=14	14 mm	Stainless steel	Piece(s)
17LV3=16	16 mm	Stainless steel	Piece(s)
17LV3=20	12 mm	Stainless steel	Piece(s)

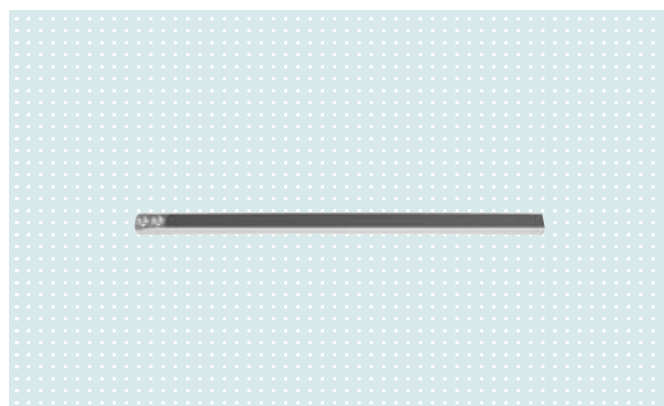

▶ 17LV3 side bar



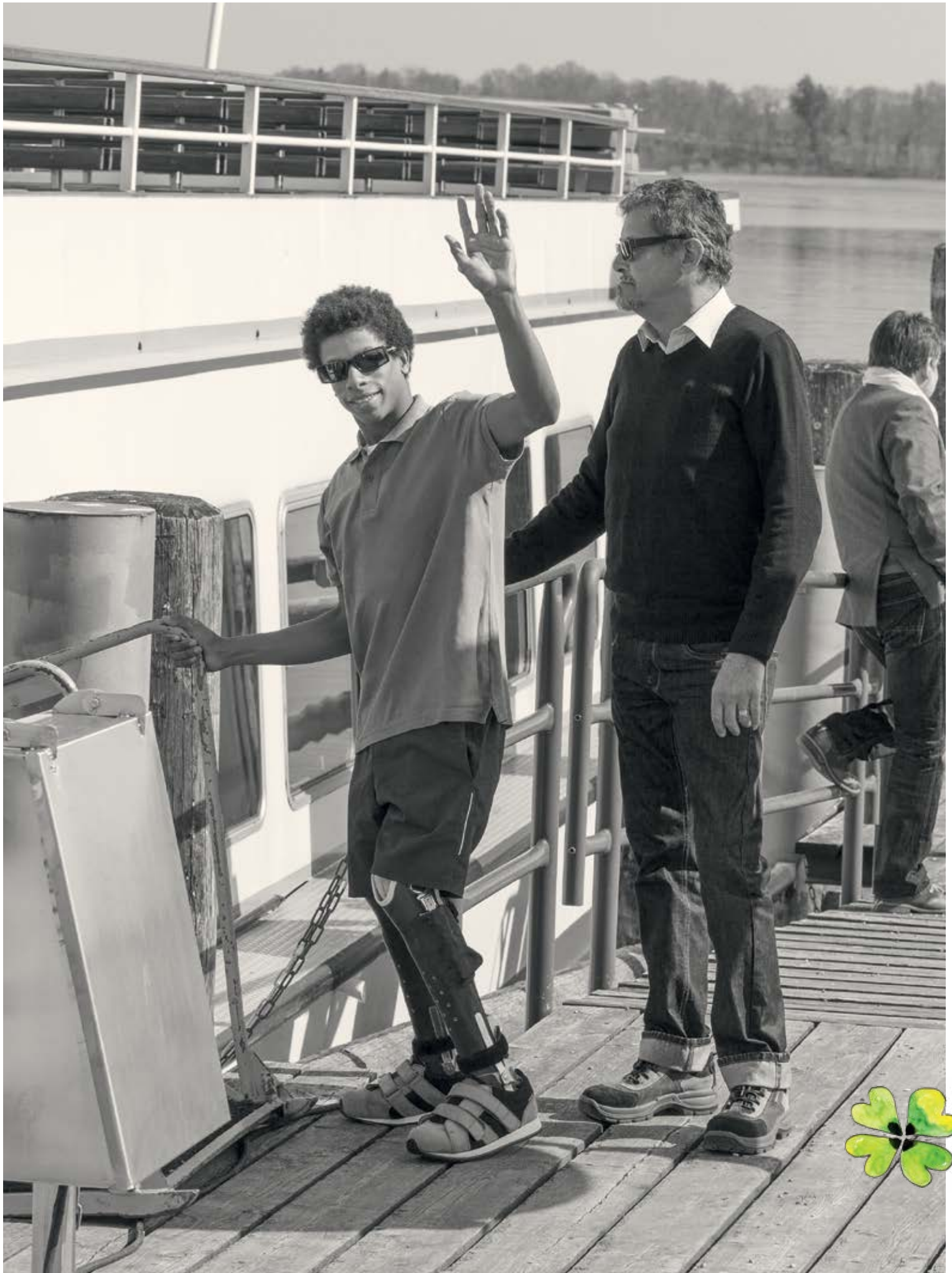

# CarbonIQ knee and ankle joints

## CarbonIQ joint system

Experience progress

The CarbonIQ joint system uses a proven technical thermo-plastic strengthened with carbon fibre. It therefore combines the benefits of plastic and carbon to form an innovative, high-quality material combination for knee and ankle joints.

### 17PA1 CarbonIQ ankle joint

#### Special features

- Ankle joint with nine different adjustment and combination possibilities
- Functionality not impaired by splashed water
- Lightweight
- Used and delivered in pairs
- 14 mm splint width for children, 20 mm splint width for adults



17PA1 CarbonIQ ankle joint

Article number	Side	Max. body weight	Material	Unit
17PA1=14	Left, right	45 kg	Fibre-reinforced plastic	Pair
17PA1=20	Left, right	100 kg	Fibre-reinforced plastic	Pair

## Accessories

### 17PF1 Foot stirrup

Article number	For	Material	Unit
17PF1	17PA1=20	Stainless steel	Piece(s)
17PF1=14	17PA1=14	Stainless steel	Piece(s)

#### Our recommendation

The CarbonIQ ankle joint can be combined with:

- 17PK1 CarbonIQ knee joint

## 17PK1 CarbonIQ knee joint

### Special features

- Concealed lock with pull-release cable for a high level of safety
- User-friendly
- Lightweight
- Functionality not impaired by splashed water
- Used and delivered in pairs
- 14 mm splint width for children, 20 mm splint width for adults

### Medial and lateral joint, straight

Article number	Max. body weight	Material	Unit
17PK1=14	45 kg	Plastic reinforced with carbon fibre	Pair
17PK1=20	100 kg	Plastic reinforced with carbon fibre	Pair



17PK1 CarbonIQ knee joint



### Our recommendation

The CarbonIQ knee joint can be combined with:

- 17PA1 CarbonIQ ankle joint



# Waterproof knee and ankle joints

---

## Aqualine orthosis system

The solution for wet areas



It is important for children to learn to swim, to participate in water aerobics if necessary and to be able to shower independently when they are at home or travelling. That is why the Aqualine orthosis system is also available in a version for children (14 mm splint width).

The waterproof versions of the CarbonIQ knee and ankle joints form the heart of the Aqualine. The individual components are resistant to corrosion; chlorine, salt water and soap do not impair their functionality.





• 17PK1=\* WR waterproof CarbonIQ knee joint with wedge lock



• 17PA1=\* WR waterproof CarbonIQ ankle joint

### 17PK1=\* WR Waterproof CarbonIQ knee joint with wedge lock

Article number	Side	Max. body weight	Material	Unit
17PK1=L14	Left	45 kg	Fibre-reinforced plastic	Pair
17PK1=R14	Right	45 kg	Fibre-reinforced plastic	Pair
17PK1=L20	Left	100 kg	Fibre-reinforced plastic	Pair
17PK1=R20	Right	100 kg	Fibre-reinforced plastic	Pair

- For waterproof walking aids
- Concealed lock with pull-release cable for a high level of safety
- User-friendly
- Lightweight
- Used and delivered in pairs
- 20 mm splint width for adults, 14 mm splint width for children

### 17PA1=\* WR Waterproof CarbonIQ ankle joint

Article number	Side	Max. body weight	Material	Unit
17PA1=14	Left, right	45 kg	Fibre-reinforced plastic	Pair
17PA1=20	Left, right	100 kg	Fibre-reinforced plastic	Pair

- For waterproof walking aids
- Ankle joint with nine different adjustment and combination possibilities
- Lightweight
- Used and delivered in pairs
- 20 mm splint width for adults, 14 mm splint width for children

# Waterproof knee and ankle joints

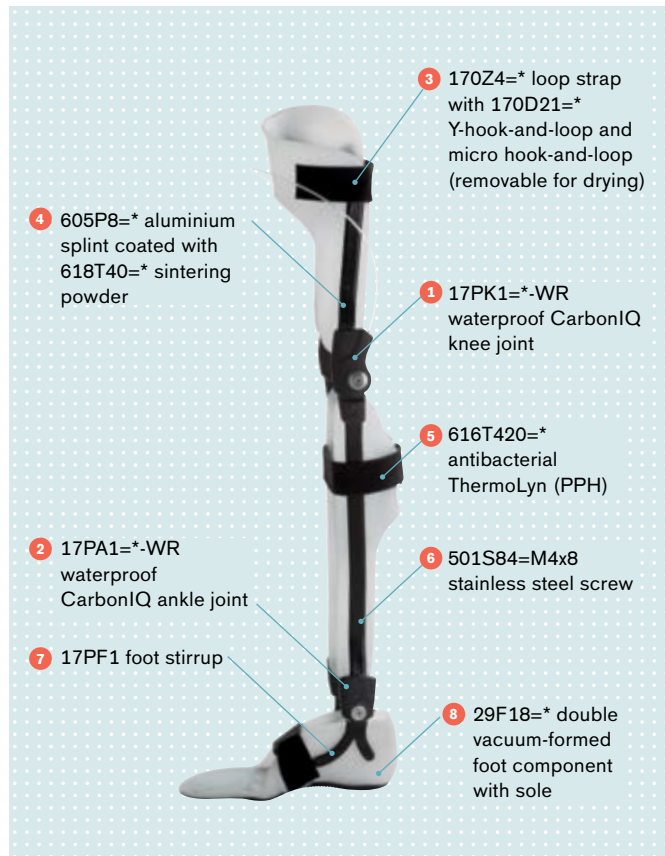

## 3 170Z4=\* Loop strap

Article number	Length	Material	Colour	Unit
170Z4=400-7	400 mm	Polyamide	Black	Piece(s)
170Z4=600-7	600 mm	Polyamide	Black	Piece(s)

## 4 605P8=\* Aluminium bar

Suitable for fabricating system splints, with rounded edges, strength approx. 400 N/mm<sup>2</sup>

Article number	Length	Width	Thickness	Unit
605P8=14	2,000 mm	14 mm	5 mm	Piece(s)
605P8=20	2,000 mm	20 mm	5 mm	Piece(s)

## 5 616T420=\* Antibacterial ThermoLyn

Polypropylene homopolymer

Article number	Length	Width	Colour
616T420=5	2,000 mm	5 mm	Natural colour
616T420=6	2,000 mm	6 mm	Natural colour

## 6 501S84=\* Stainless steel screw

Suitable for fabricating system splints, with rounded edges, strength approx. 400 N/mm<sup>2</sup>

Article number	Unit
501S84=M4x8	Piece(s)

## 7 17PF1=\* Foot stirrup

Article number	For	Material	Unit
17PF1	17PA1=20	Stainless steel	Piece(s)
17PF1=14	17PA1=14	Stainless steel	Piece(s)

## 8 29F18=\* Foot component

Article number	Side	Size	Material	Unit
29F18=L	Left	37-40 40-43 43-46	Rubber plate with crepe profile	Piece(s)
29F18=R	Right	37-40 40-43 43-46	Rubber plate with crepe profile	Piece(s)

### Our recommendation

- All components in a waterproof walking aid should be waterproof and easy to wash
- We generally recommend the use of a full-surface, non-skid sole or a bathing shoe as well as the use of the knee joints with lock
- We recommend the use of antibacterial materials.
- The waterproof walking aid should minimise skin contact







# HKAFO – RGO hip joint system

---

## RGO hip joint system



The connection between the leg bars and the pelvic module is especially important for fittings with reciprocating gait orthoses. The RGO (reciprocating gait orthosis) hip joint system helps users achieve pelvic rotation that imitates physiological rotation during walking. Thanks to the development of a bi-axial joint construction, pelvic rotation of 15° is possible without having to change the walking direction. This results in less effort and a more effective gait pattern.

### **Application**

The reciprocating hip joint system was specifically designed for patients with a body weight of up to 65 kg. It can be used with patients who have spina bifida or myopathies originating from other causes (e.g. traumatic paraplegia) with a lesion level of Th5 to L3. Restrictions must be made for patients with ICP, motor perception disorders, deficits of movement of the upper limbs, insufficient muscle strength in the shoulder girdle, loss of trunk mobility in the frontal or sagittal plane, severe deformities of the skeletal system (e.g. scoliosis, dislocations), hip flexion contracture (> 20°), knee joint flexion contracture (> 15°), and torsional deformities of the legs.

## 17H100 RGO hip joint system

Article number	Body weight	Pelvic width	Age	Unit
17H100=0	Up to 65 kg	340–380	9 years and up	Set
17H100=1	Up to 65 kg	270–330 mm	9 years and up	Set
17H100=2	Up to 34 kg	200–260 mm	4–8 years	Set

- Please note that the pelvic tube is not included in the scope of delivery and must be ordered separately.

### Special features of the RGO hip joint system

- Easy to use thanks to modular system
- Separate components allow the orthosis to grow with the child
- Pelvic tube made of lightweight alloy with high torsional strength allows for modular connection of joints
- The bi-axial system allows for a pelvic rotation of 15° in the orthosis without changing the walking direction.
- Push-pull cable system aids in smooth and maintenance-free power transmission during walking
- Sitting joint lock release with pre-release of the locking mechanism
- Safety button for re-locking in case of accidental pre-release of the sitting joint
- Choice of thermoplastic or laminate materials for the integration of an individually fabricated pelvic module
- Torso bars are easily disassembled
- Torso bar hip flexion adjusts up to 10°
- Prefabricated thigh bars made of lightweight alloy with 0 mm, 5 mm and 10 mm offset available



• 17H100 RGO hip joint system



# HKAFO – Locked joint

## 17HL5 Hip joint bar with double lock



These hip joint bars are intended for children who exhibit severe instability of the torso musculature even while sitting and are not able to independently hold their trunk in the A-P plane. Locking at 90° helps improve stability while sitting.

Article number	Bar length, upper/lower section	Bar width/thickness	Material	Unit
17HL5=13-CS	300/250 mm	13/5 mm	Stainless steel	Pair
17HL5=14-CS	340/300 mm	14/5.5 mm	Stainless steel	Pair

The hip joint bars are supplied in pairs and equipped with a double spring lock for locking at 90° (for stable sitting) and 180° (for stable standing).





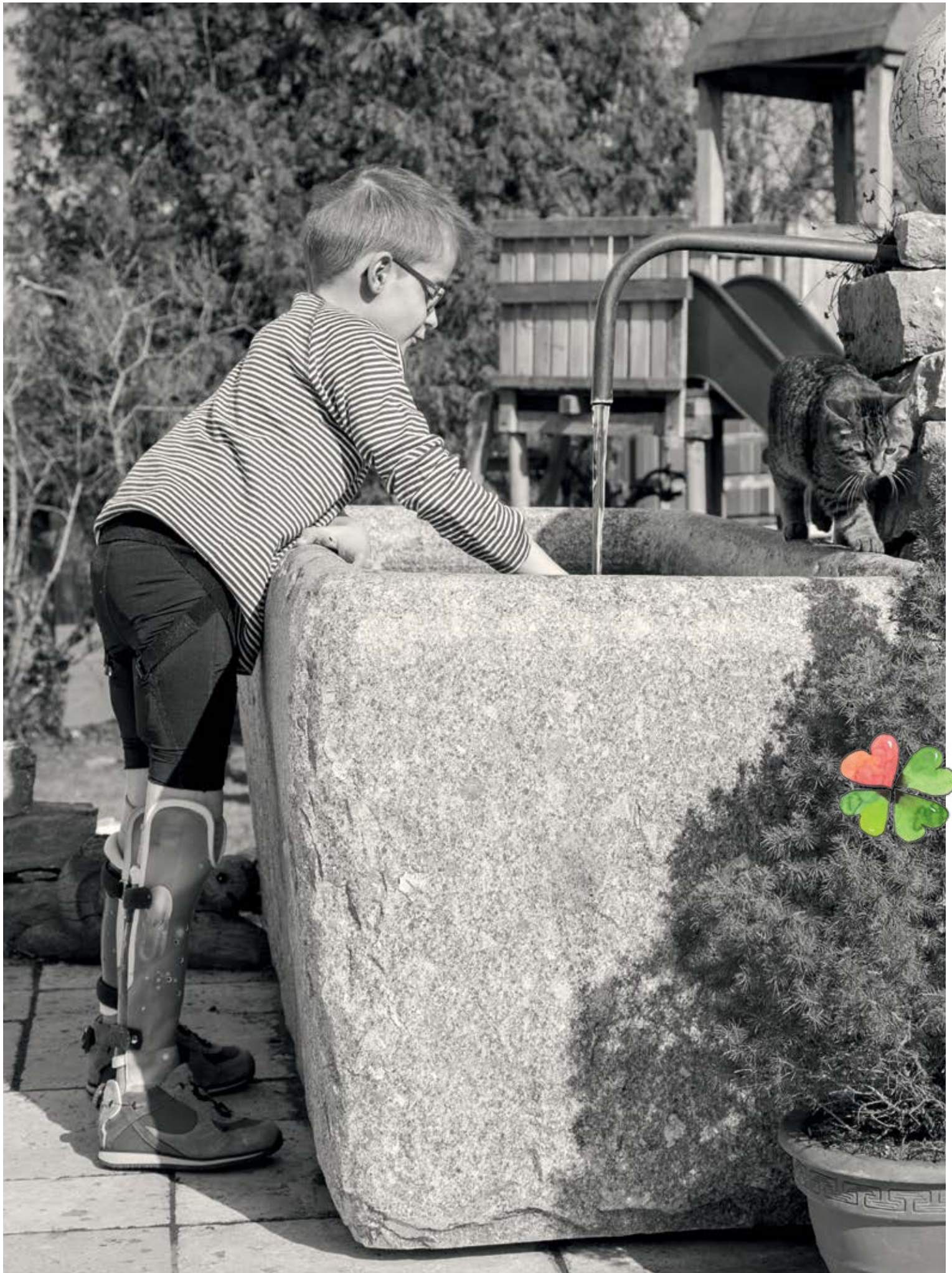



# HKAFO – Hip abduction orthosis

## Cosa Active/Junior

Supports patients with neuromuscular diseases

The use of pads between the legs significantly reduces hip adduction, which, along with improved trunk control, helps to stabilise the standing and sitting base.

Thanks to the orthosis, ambulatory patients can use less energy to cover greater distances. In addition, the improved pelvic symmetry and increased freedom of knee movement support a more physiological gait. The Cosa Active/Junior abduction orthosis is also helpful for wheelchair users, as its design makes additional wheelchair pommels unnecessary. Patients with neuromuscular weakness often have a narrower – and thus less stable – sitting base in their wheelchair, which makes it necessary for them to use their hands. By wearing this orthosis, however, patients not only gain a wider seating position, but also greater freedom for their hands, making it easier to eat, play, write or use electronic devices.

### Application

- Diplegia, spastic
- Hip dysplasia
- Hip joint subluxation, congenital
- Hypotonicity
- Tetraplegia, spastic

### Exclusion criterion

- Hip luxation

### Special features

- Improved mobility through minimisation of scissor gait (more knee freedom, improved gait pattern)
- Improved torso control
- More stable base for sitting and standing
- Can be combined with orthoses
- Can be worn day and night
- Easy to adjust
- Easy care, machine washable (in a laundry bag) at 40 °C
- Good patient compliance thanks to a high level of wearer comfort



### Our recommendation

The Cosa Active/Junior hip abduction orthosis can be combined with:

- Custom/prefabricated AFOs



### Fitting by the O&P professional

The Cosa Active/Junior is generally delivered in a 28L101=\* / 28L100=\* starter set. The set contains two pairs of 29L101=\* / 29L100=\* trousers for changing and washing, and includes the 29L102=\* pad set.

When fitting the Cosa Active/Junior for your customers, the individual patient measurements are just as important as the final fitting of the device. The off-the-shelf size is the starting point for determining the trouser size. The pads included in the starter set are also based on this size.

The Cosa Active/Junior also offers other, individual fitting options to help achieve the best possible wearer comfort.

For you, this means:

- The trousers can be further adapted
- Straps that have been positioned appropriately can be sewn in place
- The pads can be sanded to offer the patients optimal support



Without Cosa Active



With Cosa Active

### Sizing chart

Size	28L100=* Cosa Junior				28L101=* Cosa Active						
	80	92	104	116	128	140	152	S	M	L	
Standard sizing	80	92	104	116	128	140	152	164 Women 34 Men 42	Women 36, 38 Men 44, 46	Women 40, 42 Men 48, 50	Women 44, 46 Men 52, 54
Body height (cm)	74–86	86–98	98–110	110–122	122–134	134–146	146–158	158–170			
Hip circumference (cm)	57–59	59–62	62–64	64–68	68–72	72–78	78–86	86–96	96–105	105–109	
Pad number	1	2	3	4	5						
Thigh circumference (cm)	26–32	32–36	36–44	44–54	54–62						

# Upper limb fittings

ICP also often causes movement and functionality limitations in the upper limbs. You can create individual, functional solutions for supporting the gripping and lifting functions with the selection of products presented below.

## 16X12 Elbow joint bars



One joint bar has a swivelling cable lock and 18 locking positions in 7.2° increments. The second joint bar has no lock. Both joint bars can be used on either side and are suitable for prostheses.

Article number	Head diameter	Unit
16X12	30 mm	Piece(s)

**1 16X13 Elbow joint bar with cable lock**  
Joint with swivelling cable lock, 18 locking positions in 7.2° increments, flat bar profile, suitable for both sides, for prostheses

Article number	Head diameter	Material	Unit
16X13	30 mm	Stainless steel	Piece(s)

**2 16X14 Elbow joint bar without lock**  
Free motion joint, flat bar profile, joint bar

Article number	Head diameter	Material	Unit
16X14	30 mm	Stainless steel	Piece(s)



## Spare parts and accessories for 16X12, 16X13, 16X14

### 16Y27 Joint piece with cable lock

18 increments, approx. 7.2° each – suitable for both sides

Article number	Unit
16Y27	Piece(s)



▶ 16Y27 joint piece with cable lock



▶ 16Y31 joint piece without lock

### 16Y31 Joint piece without lock

Article number	Unit
16Y31	Piece(s)

### 16Y26 Pull cable

Article number	Unit
16Y26	Piece(s)



▶ 16Y26 pull cable



▶ 21Y79 webbing plate

### 21Y79 Webbing plate

Article number	Unit
21Y79	Piece(s)

### 16Y32 Cover cap

Article number	Material	Unit
16Y32	Plastic	Piece(s)



▶ 16Y32 cover cap



▶ 501S59 truss head screw

### 501S59 Truss head screw

Article number	Unit
501S59	Piece(s)

### 16Y29 Joint bar section

For use as upper or lower bar, suitable for both sides

Article number	Material	Unit
16Y29	Stainless steel	Piece(s)

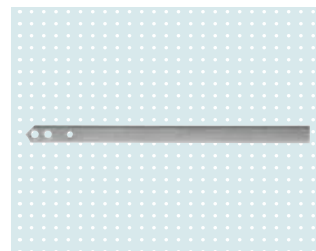

▶ 16Y29 joint bar section



▶ 16Y30 modular connector

### 16Y30 Modular connector

For use of the 16Y27 joint piece with cable lock for modular arm prosthesis

Article number	Material	Unit
16Y30	Stainless steel	Piece(s)

# Upper limb fittings

## 16X4 Arm bars

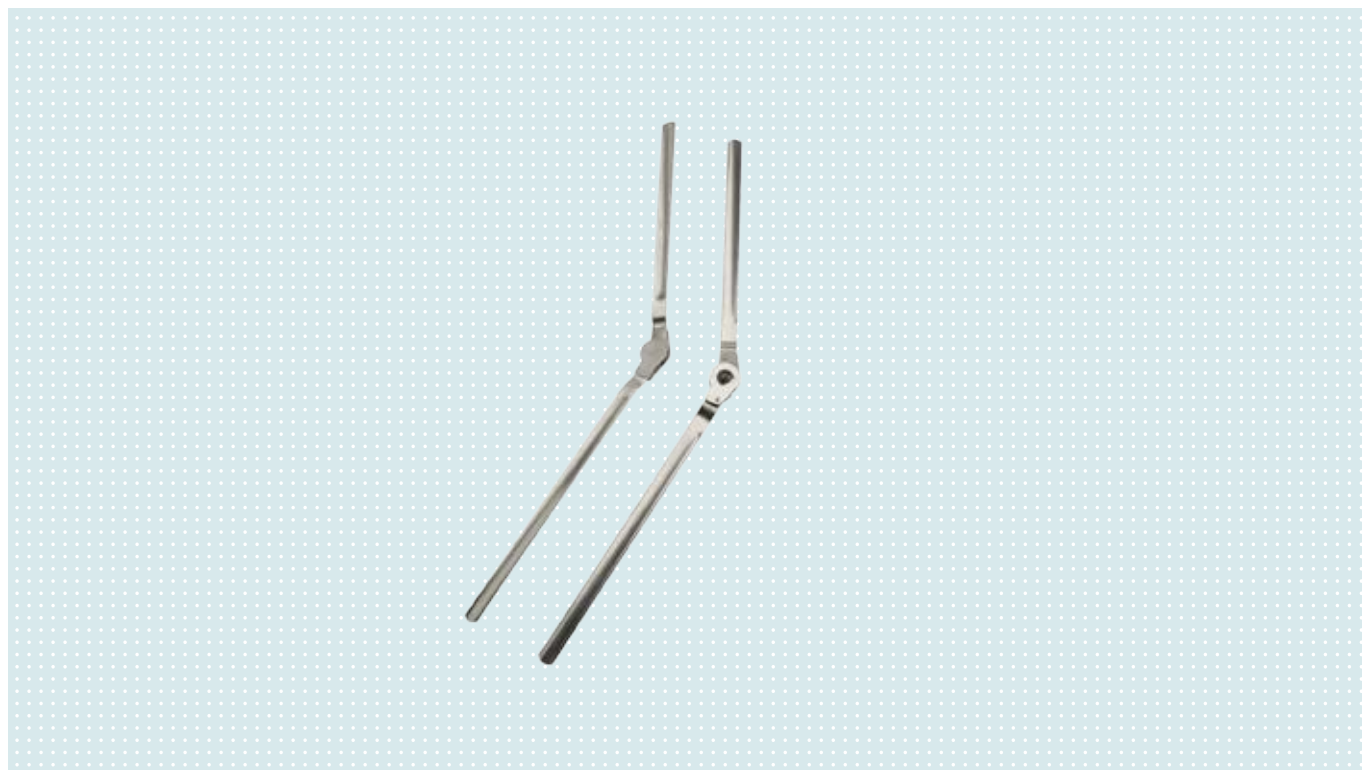

The arm bar joints have an automatic ratchet lock that locks in extension and releases at maximum flexion (approx. 135°). The bar profile is concave/half-round.

Article number	Bar width	Joint bar thickness	Head diameter	Material	Unit
16X4	14 mm	2 mm	26 mm	Stainless steel	Piece(s)

## Spare parts for 16X4

### 16Y7 Lock piece

Article number	Material	Unit
16Y7	Stainless steel	Piece(s)

### 16Y8 Lock ring

Article number	Material	Unit
16Y8	Stainless steel	Piece(s)



# 17B70 Positioning joint



The ratchet joint is adjustable in 8° increments and suitable for adjustable positioning splints and static correction orthoses.

Article number	For system width	Material	Unit
17B70=12	12 mm	Stainless steel	Piece(s)

## Spare parts for 17B70

### 16Y93 Bearing nut, hardened

Article number	Unit
17Y93=7x4.8xM5	Piece(s)

### 506A12 Rivet pin

Article number	Material	Unit
506A12=4x9	Stainless steel	Piece(s)

### 18Z3 Ring

Article number	Unit
18Z3	Piece(s)

### 651B1 Spring band steel profile bar, extension material

Article number	Length	Width	Material	Unit
651B1=12	2,000 mm	12 mm	Spring band steel	Piece(s)

### 501S57 Slotted truss head screw

Article number	Unit
501S57	Piece(s)

# Correction system joints

---

## Correction system joints

Static joints for positioning orthoses



Contracture treatment is intended to restore joint functionality and avoid deformities. The static correction joint system for the upper and lower limbs (hand, elbow, knee and ankle joints) is suitable for fittings for adults as well as children. It is used in positioning orthoses, and the joints match the common dimensions of Ottobock's portfolio of joint bars.

The individually required angles are continuously adjustable by means of a worm gear. An angle scale is provided on the joint for orientation, control and targeted adjustment of the correction.

An easy-on, easy-off system was developed for quick application and removal of the orthosis, allowing correction to be disengaged completely. You can also adjust the unlocking of the joint in extension for any stop angle. This allows for physiotherapeutic training as well as installation of a dynamic unit.



# 17BK1 Correction system joints



Article number	Side	System width	Dynamic unit	Material	Unit	Medial support
17BK1=L1	Left	20 mm	17BK2=L1	Aluminium	Piece(s)	17BK3=18
17BK1=R1	Right	20 mm	17BK2=R1	Aluminium	Piece(s)	17BK3=18
17BK1=L2	Left	16 mm	17BK2=L2	Aluminium	Piece(s)	17BK3=18
17BK1=R2	Right	16 mm	17BK2=R2	Aluminium	Piece(s)	17BK3=18
17BK1=L3	Left	14 mm	17BK2=L3	Aluminium	Piece(s)	17BK3=14
17BK1=R3	Right	14 mm	17BK2=R3	Aluminium	Piece(s)	17BK3=14
17BK1=L4	Left	12 mm	17BK2=L4	Aluminium	Piece(s)	17BK3=14
17BK1=R4	Right	12 mm	17BK2=R4	Aluminium	Piece(s)	17BK3=14

► Delivery condition: the joint is supplied with an adjustment wrench.

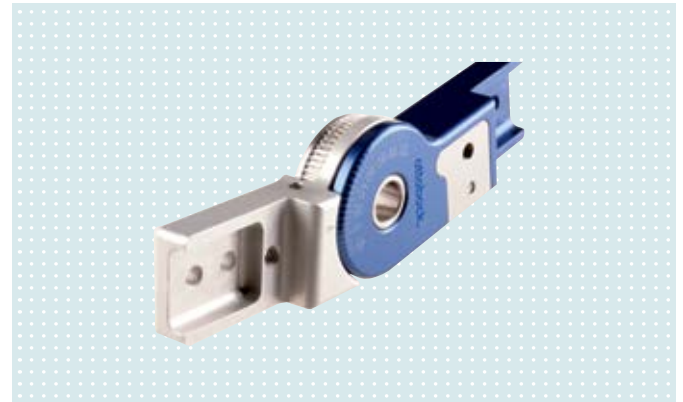

## Size recommendation

User height	Wrist joint	Elbow joint	Knee joint	Ankle joint
Children up to 1 m	=L/R4	=L/R4	=L/R4	=L/R4
Children 1–1.40 m	=L/R4	=L/R3	=L/R3	=L/R3
Adults up to 1.60 m	=L/R4	=L/R3	=L/R2	=L/R2
Adults 1.60–1.90 m	=L/R3	=L/R2	=L/R1	=L/R1

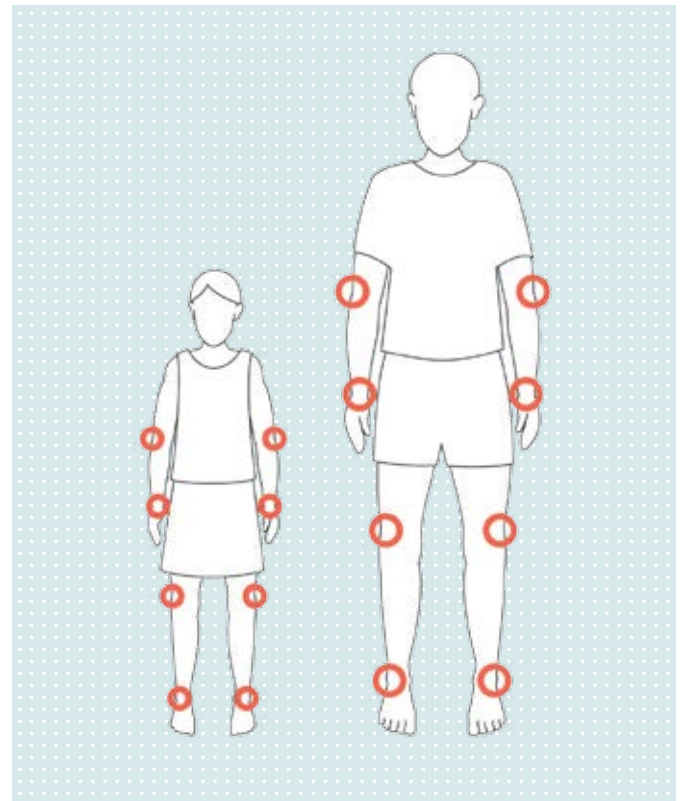

### ► Attention:

This information merely constitutes a recommendation. The correct size for the respective patient must be determined and specified by the O&P professional in each case. The joints are used individually or in pairs depending on the application. We recommend always using a medial support, e.g., an integrated plastic joint. Bilateral fitting (in pairs) is mandatory for knee and ankle joint fittings. The left/right side indications refer to the application of the joints on the wrist, knee joint or ankle joint. To accommodate the anatomical shape of the elbow, the sides must be reversed for elbow applications (right to left and left to right).

# Correction system joints

## Accessories for 17BK1

### 17BK2 Dynamic unit for correction system joint

The 17BK2 dynamic unit is available for all four sizes of the 17BK1 static correction system joint and, depending on the joint size, offers a maximum spring force of approx. 10 Nm.

Use of the 17BK2 dynamic unit allows for extension or flexion yielding, depending on the joint and indications. Spring force is used to slowly bring the joint back into the desired position.

The spring is continuously adjustable, allowing for individual dynamic treatment of contractures.



Article number	Side	System width	Dynamic unit	Material	Unit	Medial support
17BK1=L1	Left	20 mm	17BK2=L1	Aluminium	Piece(s)	17BK3=18
17BK1=R1	Right	20 mm	17BK2=R1	Aluminium	Piece(s)	17BK3=18
17BK1=L2	Left	16 mm	17BK2=L2	Aluminium	Piece(s)	17BK3=18
17BK1=R2	Right	16 mm	17BK2=R2	Aluminium	Piece(s)	17BK3=18
17BK1=L3	Left	14 mm	17BK2=L3	Aluminium	Piece(s)	17BK3=14
17BK1=R3	Right	14 mm	17BK2=R3	Aluminium	Piece(s)	17BK3=14
17BK1=L4	Left	12 mm	17BK2=L4	Aluminium	Piece(s)	17BK3=14
17BK1=R4	Right	12 mm	17BK2=R4	Aluminium	Piece(s)	17BK3=14

### 17BK3 Medial support for correction system joint

Article number	Material	Unit
17BK3=14	Aluminium	Piece(s)
17BK3=18	Aluminium	Piece(s)

- Please note that the size and side of the static and dynamic units must be identical



## “Tabaluga” thermopaper

- For custom colouring of synthetic materials such as ThermoLyn PE 200, ThermoLyn PP-C and ThermoLyn PP-H
- Large selection of unique designs in red, green, blue and white
- Environmentally friendly, tear-proof paper
- No additional workshop equipment or special technical knowledge required

### Our recommendation

Warm the synthetic material until it is completely transparent. Cut the thermopaper to size and apply it, with the design facing down, onto the precut component; carefully smooth the thermopaper from the middle towards the outside edges. After approx. 20 seconds, pull the thermopaper off the material.

### 623P110 Thermopaper

Reference number	623P110=2-*	623P110=5-*
Length	2 m	5 m
Width	75 cm	75 cm
Colour	Red (2), green (3), blue (5), white (6)	Red (2), green (3), blue (5), white (6)

Example for ordering

Reference number	=	Length	-	Colour
623P110	=	2	-	2



Red (2)



Green (3)



Blue (5)



White (6)



# Socket decor

## “Tabaluga” socket decor

- For custom colouring with lamination technique
- Large selection of unique designs
- Proven tubular fabric
- No special workshop equipment or special technical knowledge required

### Our recommendation

In order to laminate socket decors, they may be sewn up and used as the first and/or last layer of the laminate like a stockinette, with the design facing the visible side.

### 623S110 Socket decor

Reference number	623S110=15-*	623S110=20-*
Length	1.5 m	1.5 m
Width	15 cm	20 cm
Colour	Red (2), green (3), blue (5), white (6)	Red (2), green (3), blue (5), white (6)

Example for ordering

Reference number	=	Width	-	Colour
623S110	=	15	-	2



◦ Red (2)



◦ Green (3)



◦ Blue (5)



◦ White (6)

## 21Y75N Polyurethane hook-and-loop closure

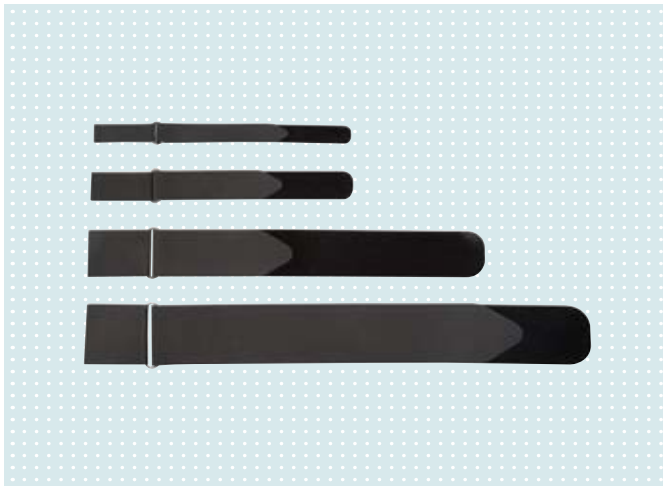

### Benefits at a glance

- Polyamide with PU coating
- Heavy-duty hook-and-loop
- With strap guide loop
- Can be refastened many times
- User-friendly thanks to hook notch at the beginning of the closure
- Very high hook-and-loop strength
- Individually adaptable length
- Abrasion-proof, smooth surface
- Easy to clean thanks to PU coating
- Not bulky
- Washable with a damp cloth
- Attractive design
- Various dimensions available

### 21Y75N Polyurethane hook-and-loop closure

Article number	21Y75N= 280X16-7	21Y75N= 280X25-7	21Y75N= 400X40-7	21Y75N= 680X50-7
Colour	Black (7)	Black (7)	Black (7)	Black (7)
Length	280 mm	280 mm	400 mm	680 mm
Width	16 mm	25 mm	40 mm	50 mm



### Our recommendation

The polyurethane hook-and-loop closure can be combined with:

- Custom/prefabricated AFOs and KAFOs









© 2016 Tabaluga Enterprises GmbH  
TABALUGA is based on an idea from Peter Maffay,  
Gregor Rottschalk, Rolf Zuckowski and Helme Heine.  
[www.tabaluga-enterprises.de](http://www.tabaluga-enterprises.de)

Ottobock SE & Co. KGaA  
Max-Näder-Straße 15  
D-37115 Duderstadt, Germany  
[export@ottobock.com](mailto:export@ottobock.com)  
[www.ottobock.com](http://www.ottobock.com)